

# ***Yamato***<sup>®</sup>

## **Instruction Manual**

HIGH SPEED CYLINDER BED 3-NEEDLE  
INTERLOCK STITCH MACHINE WITH TOP FEEDING

# **VGS2700-8 class**

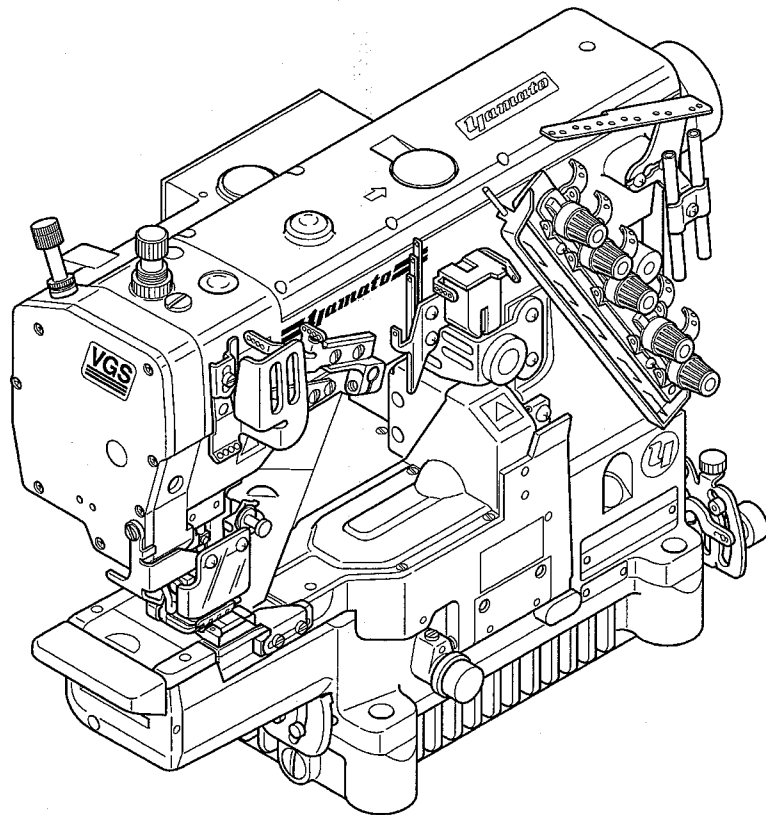







Thank you for having purchased the Model VGS2700-8 class.  
Before using your VGS 2700-8 class, please read the  
instruction manual and understand the contents well.  
After reading the instruction manual, please keep it in a  
location where it is easily accessible to the operator.

# CONTENTS

Safety instructions

i – iv

<b>1. Name of each part</b>	<b>1</b>
<b>2. Installation</b>	<b>2</b>
2.1 Table cutting diagram	2
2.1.1 Table top type (Type A: standard)	2
2.1.2 Table top type (Type B)	3
2.1.3 Semi-submerged type	4
2.1.4 Semi-submerged type with compact motor	5
2.2 Table top type	6
2.3 Semi-submerged type	6
2.4 Motor and belt	7
2.5 Hanging belt	7
2.6 Belt cover	8
2.7 Eye guard and finger guard	8
<b>3. Sewing speed and rotating direction of pulley</b>	<b>9</b>
<b>4. Lubrication</b>	<b>10</b>
4.1 Lubricating oil	10
4.2 Lubricating	10
4.3 Changing oil	11
4.4 Checking and replacing oil filter	11
<b>5. Proper operation</b>	<b>12</b>
5.1 Needle system	12
5.2 Installing needles	12
 5.3 Threading	13
 5.4 Adjusting thread tension	14
 5.5 Pressure of presser foot	14
5.6 Adjusting position of presser foot	14
 5.7 Adjusting movement of differential feed dog	15
 5.8 Adjusting stitch length	16
5.9 Adjusting feeding amount of top feed dog to lower feed dog	17
5.10 Position of folder	17
5.11 SP device and HR device	18
 5.12 Cleaning the machine	18

# CONTENTS

---

<b>6. Adjustments</b>	<b>19</b>
6.1 Needle thread tension	19
6.2 Top cover thread tension	20
6.3 Looper thread tension	20
6.4 Needle and spreader	21
6.4.1 Spreader	21
6.4.2 Top cover thread guide	22
6.4.2 Top cover thread eyelet	22
6.5 Distance between needle and looper	23
6.6 Using timing gauge	23
6.7 Height of needle	24
6.8 Front-and-rear position of needle and looper	24
6.9 Needle and needle guard(rear)	25
6.10 Needle and needle guard(front)	26
6.11 Height of feed dog	26
6.12 Changing range of differential ratio	27
6.12.1 Differential ratio 1:1.4 - 1:1.8	27
6.12.2 Differential ratio 1:0.6 - 1:1.1	28
6.13 Presser foot lift	29
6.14 Changing fabric presser	30
6.15 Clearance between top and lower feed dogs	30
6.16 Pressure of top feed dog	30
<b>7. Specifications</b>	<b>31</b>

---

## Attention

◇ This instruction manual is designed mainly for technicians, but it is advisable that also operators read the instructions with  mark to use the machine properly.

◇ The numbers in lower left corners of figures are figure numbers. We use them in texts as needed for your reference.

## Attention

The description in this instruction manual is subject to change for improvements of the commodity without notice.



# Safety instructions



## 1. To ensure safe use

Always observe the following instructions to ensure the safe use of the industrial sewing machines and devices.

### 1-1 Application and purpose

The sewing machine is designed to improve productivity in the sewing industry and must not be used for other applications and purposes. Do not use this sewing machine until it can be confirmed that safety measures for the drive units have been taken.

### 1-2 Before use

Read all instruction manuals thoroughly before starting the use of this machine and follow them.

Also, read the instruction manual for the installed drive unit.

### 1-3 Working environment

DO NOT WORK IN THE FOLLOWING ENVIRONMENTS:

- Place where atmosphere temperature and humidity give a bad influence the performance of sewing machines.
- Outdoors and place where the sewing machines are exposed to sunlight directly.
- Atmosphere containing dust, corrosive gases or flammable gases.
- Place where voltage fluctuation exceeds  $\pm 10\%$  of the rated voltage.
- Place where power capacity necessary for the used motor specifications cannot be secured.
- Place where strong electric or magnetic fields are generated such as near large-output high frequency transmitters or high frequency welding machines.

### 1-4 Unpacking and transportation

- (1) Unpack from the top.
- (2) Never hold the parts near the needle or threading parts when removing the sewing machine head from the buffer of box.
- (3) When carrying the sewing machine head, have an assistant.
- (4) Pay attention not to get excessive impact or shock when moving the sewing machine

head with a pushcart.

## 2. Installation and preparation

### 2-1 Instruction and training

Operators and workers, who supervise, repair or maintain the machine head and machine unit, are required to have the adequate knowledge and operation skills to do the job safely. In order to establish such necessary conditions, it needs for the employer to plan and enforce the safety education and training to those workers.

### 2-2 Sewing table and motor

- (1) Prepare a machine table that has enough strength to withstand the weight of the sewing head and any reaction while operating.
- (2) Maintain a comfortable working environment with considering the lighting and the arrangement of sewing machine so that the operators can work smoothly.
- (3) When installing the control box and the related parts on the sewing machine, take care about the posture of the worker.
- (4) Install the drive unit correctly according to the instruction manual.

### 2-3 Wiring

- (1) Never connect the plug for power supply until assembly is finished.
- (2) Fix the connectors securely to the sewing machine head, motor, and electric apparatus.
- (3) Do not apply excessive force to the connection cords.
- (4) Connect the cords away from the driving parts.
- (5) Place the ground wire securely to the designated position on the machine head.

### 2-4 Before operation

- (1) Take care not to attach lubricant, silicone oil, and grease on the eyes or skin.



# Safety instructions



Keep them away from children.

- (2) Be sure to fill or drop lubrication oil before operating the sewing machine. Use the Yamato SF oil as specified.
- (3) Never put your hand under the needle or near the moving parts of the machine when turning on power supply switch.
- (4) When operating a new sewing machine, make sure the rotating direction of pulley agrees with the rotating-direction mark.

## 2-5 During operation

- (1) Be sure to operate the sewing machine with the safeguards such as belt cover, finger guard, and eye guard.
- (2) Never place the finger, hair or objects under the needle or close to the moving parts while operating the sewing machine.
- (3) Be sure to turn off the power supply switch when threading or replacing the needles.
- (4) Never place your hands close to the knives when operating the sewing machine with the trimming devices.
- (5) Be sure to turn off the power supply switch when terminating the sewing work or leaving the sewing machine.
- (6) If the sewing machine malfunctions, abnormal sound or smell something unusual while operating, be sure to turn off the power supply switch.

## 2-6 Removal

- (1) Turn off the power supply switch if removed or replaced any parts or during adjustment of sewing machine.
- (2) Do not pull the cord when removing the plug. Be sure to hold the plug itself.
- (3) A high voltage is applied inside the control box. Turn off the power supply switch and wait more than 5 minutes before opening the cover.

## 3. Maintenance, inspection, and repair

- (1) Follow the instruction manuals for maintenance, inspection, and repair.
- (2) Entrust the maintenance, inspection, and repair to specially trained personnel.
- (3) Be sure to turn off the power supply switch and make sure the sewing machine and motor completely stop before the maintenance, inspection, and repair. (If using a clutch motor, take care that the motor keeps turning for a while even after turning off the power supply switch.)
- (4) Do not modify the sewing machine by the customer's judgment.
- (5) Be sure to use original replacement parts for repairs or maintenance.

## 4. Caution signs and alert pictorial markings

This instruction manual contains the following caution signs and alert pictorial markings to prevent you from injuring yourself or the sewing machine from being damaged.

Please follow the instructions.

### 4-1 Meanings of caution signs

**WARNING** indicates potentially hazardous situations which, if not heeded, could result in death or serious injury to you and others.

**Caution** indicates hazardous situations which, if not heeded, may result in minor or moderate injury to you and others, or may result in machine damage.

**NOTE** is used to emphasize essential information.



# Safety instructions



## 4-2 Alert pictorial markings



This mark indicates the warning which, if not heeded, could result in death or Serious injury.



This mark indicates the caution for high temperature.



This mark indicates the warning which, if not heeded, could result in death or Serious injury.



High-voltage applies in the control box. This label indicates that electric shock may be caused.



This mark indicates the caution which, if not grounded, the machine or device could malfunction and could result in personal injury.

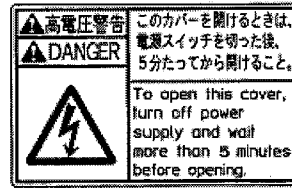

High-voltage applies in the control box. This label indicates that electric shock may be caused.



This label is affixed on the safeguards. Considering the operation, it is not affixed on the finger guard and eye guard. Be sure to



Stepping motor and solenoid may overheat if used continuously. To prevent a burn, take care not to touch.



If not connected earth line, static electricity may be generated and inflict injury on person. In addition, the malfunction of

## 5. Warning labels on sewing machines



This label indicates that removal of the safeguards and works except for sewing performance while the power supply switch is on are prohibited. (For details, see the next page.)

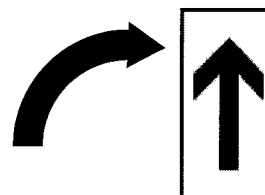

Check the rotating direction of machine pulley agrees with 'ROTATING-DIRECTION SYMBOL'.



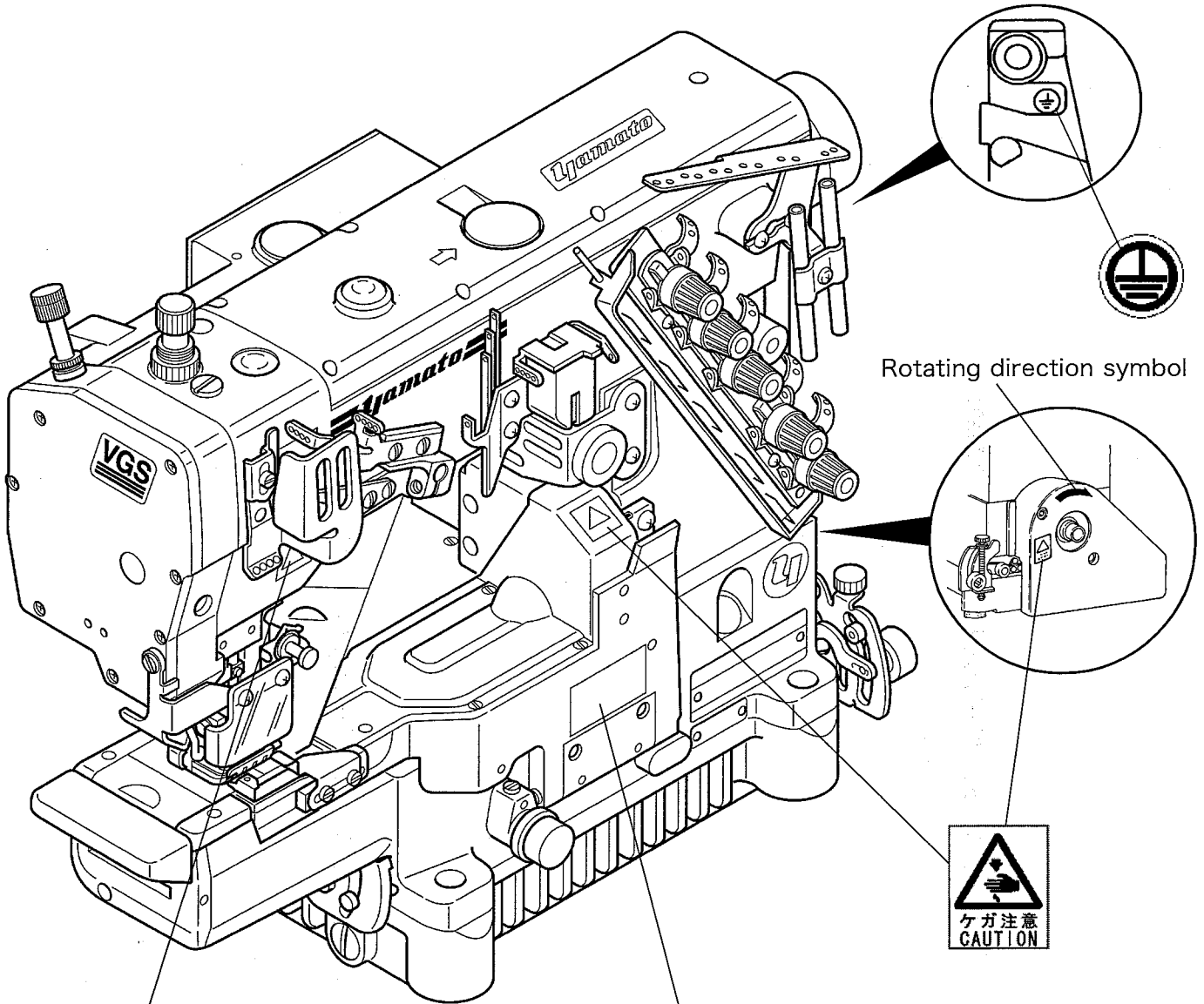

# Safety instructions



Rotating direction symbol



	<b>CAUTION</b>	
<p>Do not operate without eye guard and safety devices. Before threading, changing needle, cleaning etc. switch off main switch.</p>		

# 1. Name of each part

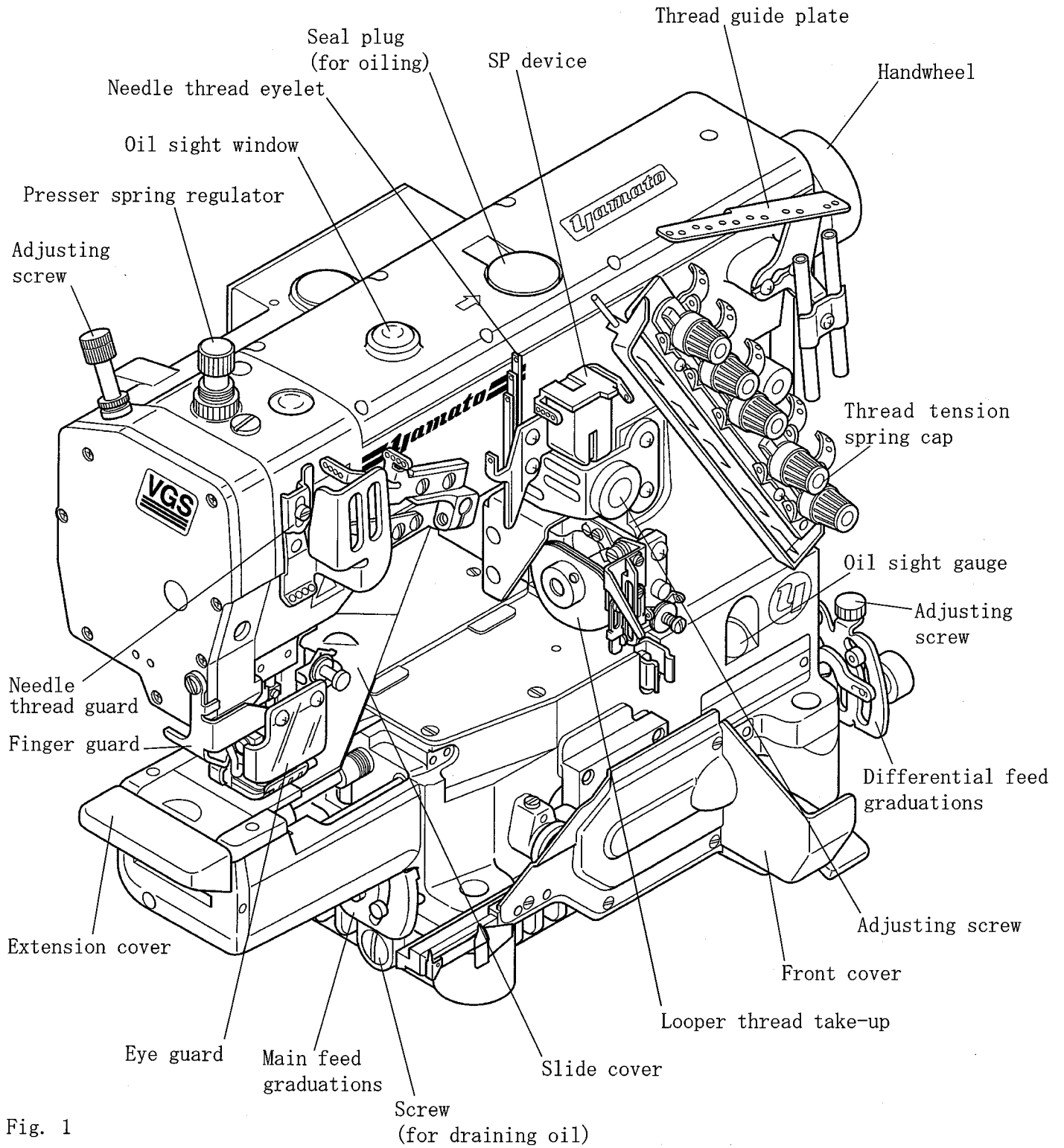

Fig. 1



# 2. Installation

## 2.1 Table cutting diagram

### 2.1.1 Table top type (Type A: standard)

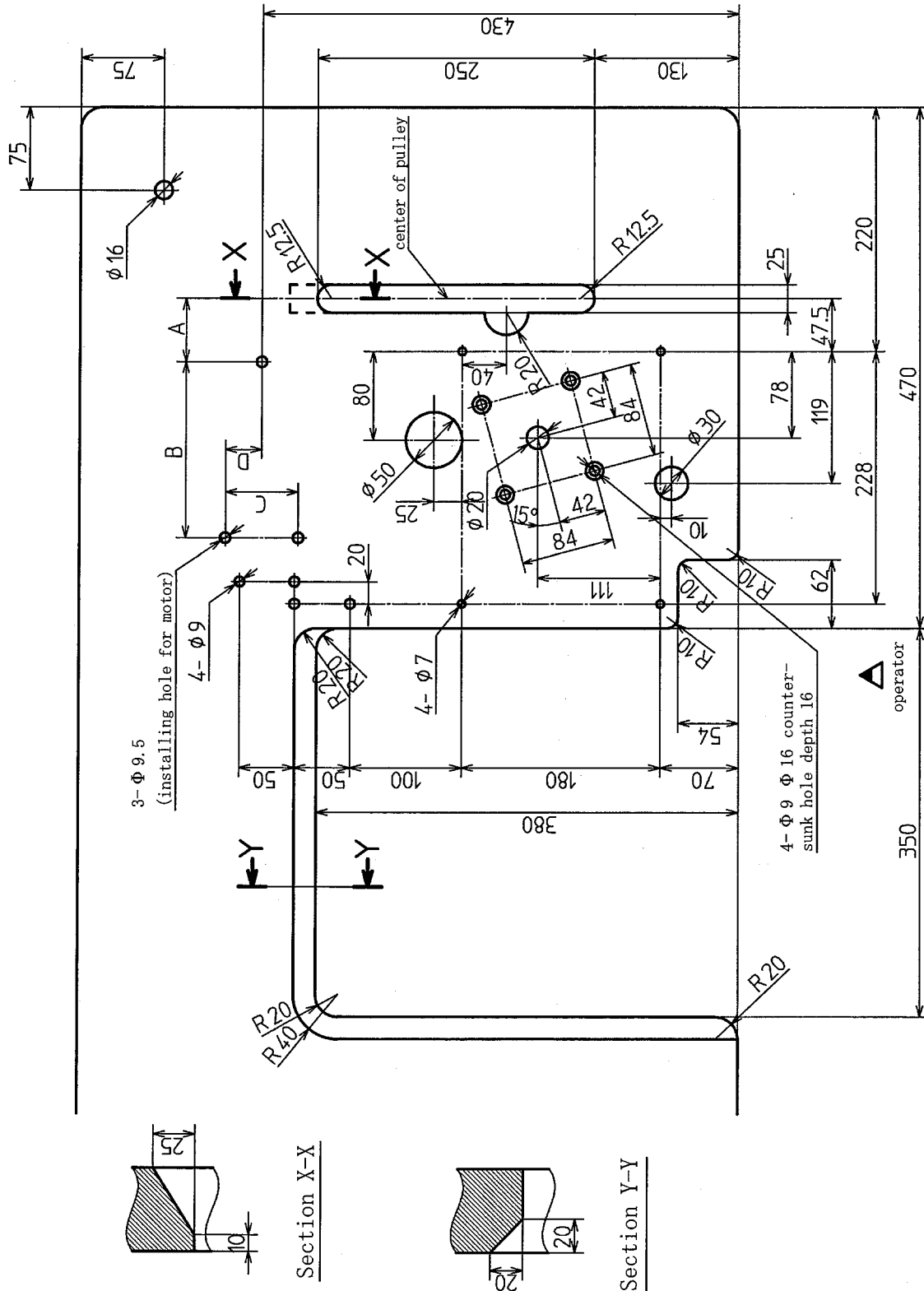

Table dimensions 1200 × 595 × 50

Refer to the instruction of the motor for dimensions A, B, C, and D.

Fig. 2

2.1.2 Table top type (Type B)

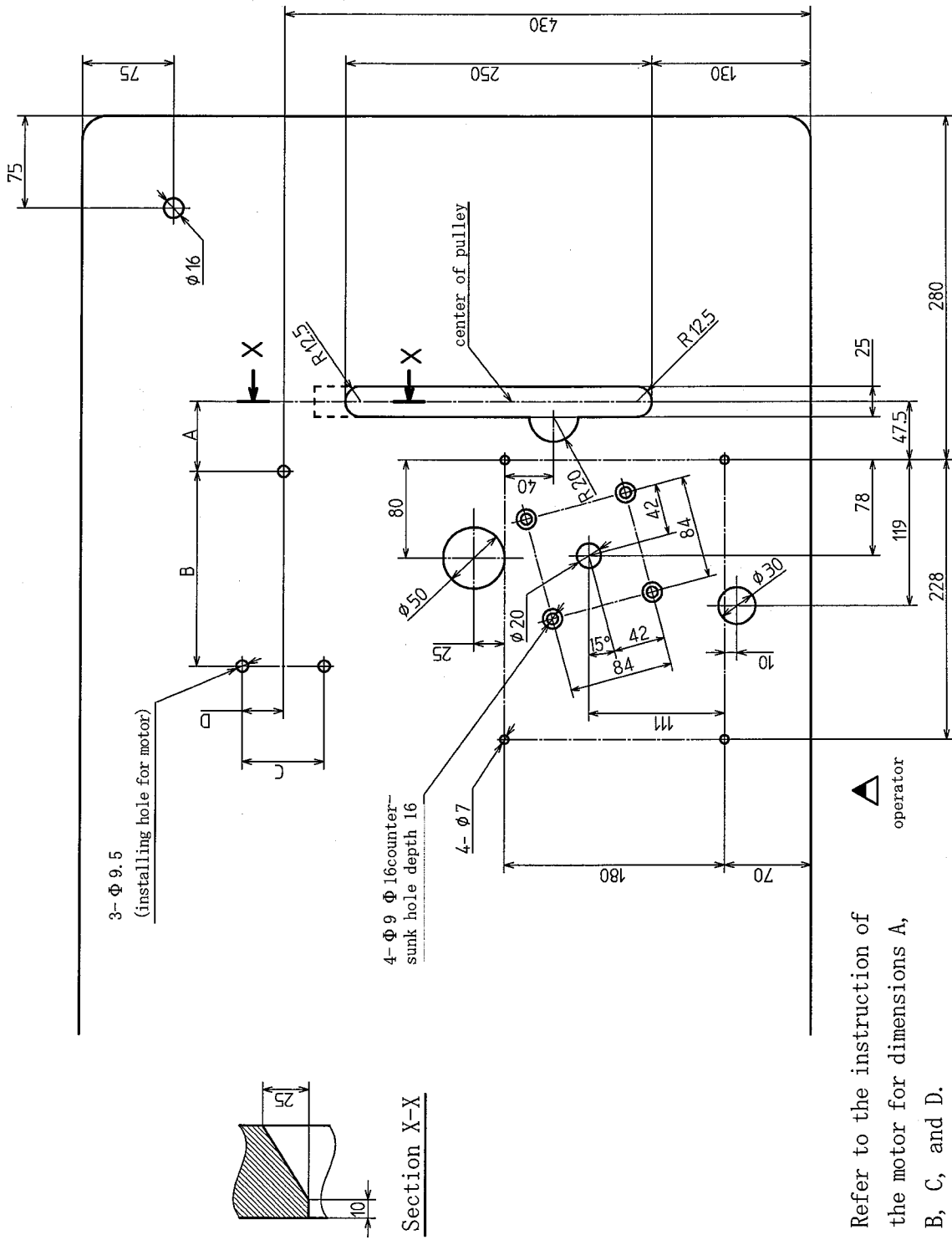

Table dimensions 1200 × 595 × 50

Fig. 3

## 2. Installation

### 2.1.3 Semi-submerged type

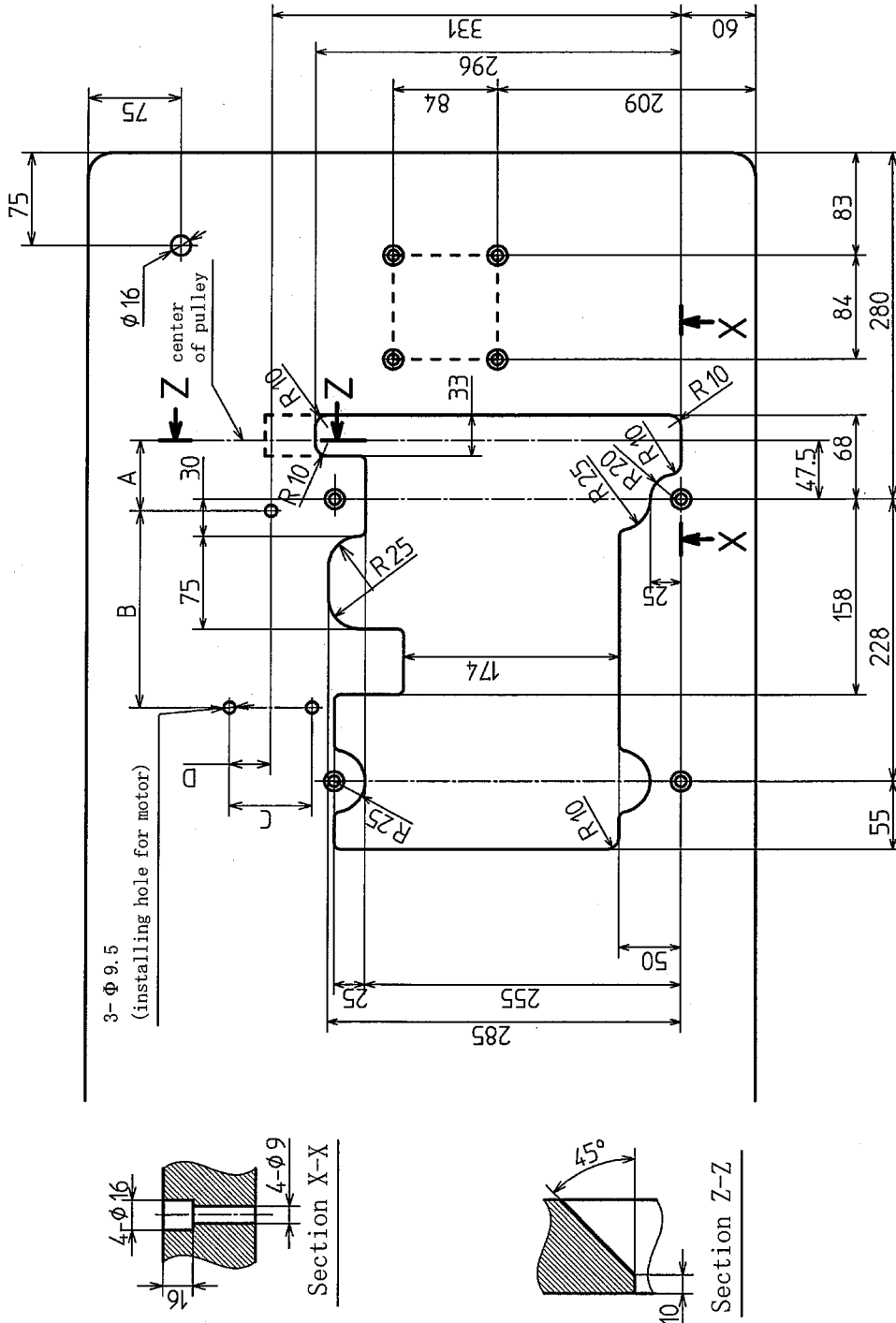

Table dimensions 1200 × 540 × 40

Refer to the instruction of the motor  
for dimensions A, B, C, and D.

Fig. 4



## 2. Installation

### 2.2 Table top type

Install a machine correctly referring to Figs. 6 and 7.

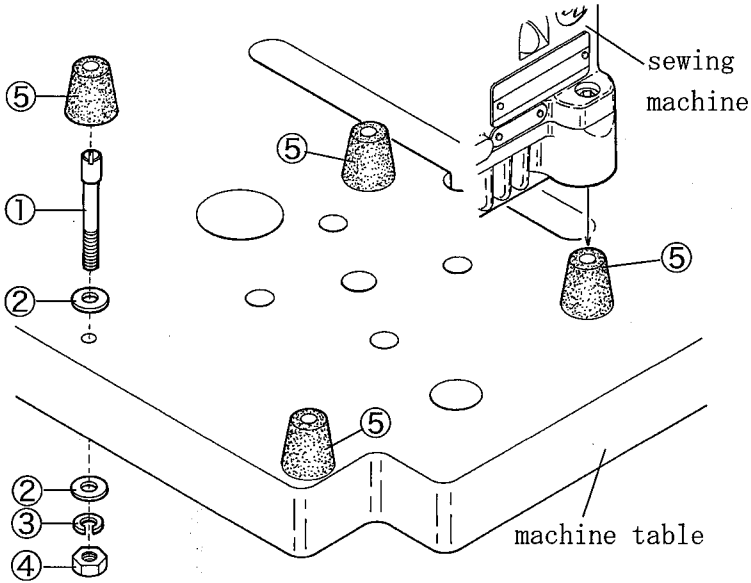

Fig. 6

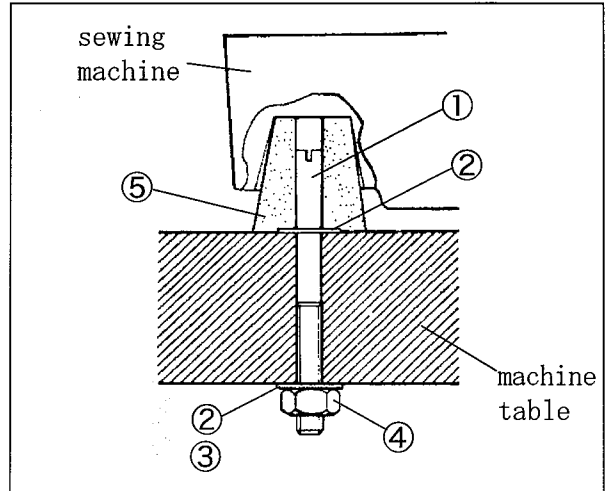

Fig. 7

### 2.3 Semi-submerged type

Install a machine correctly referring to Figs. 8 and 9.

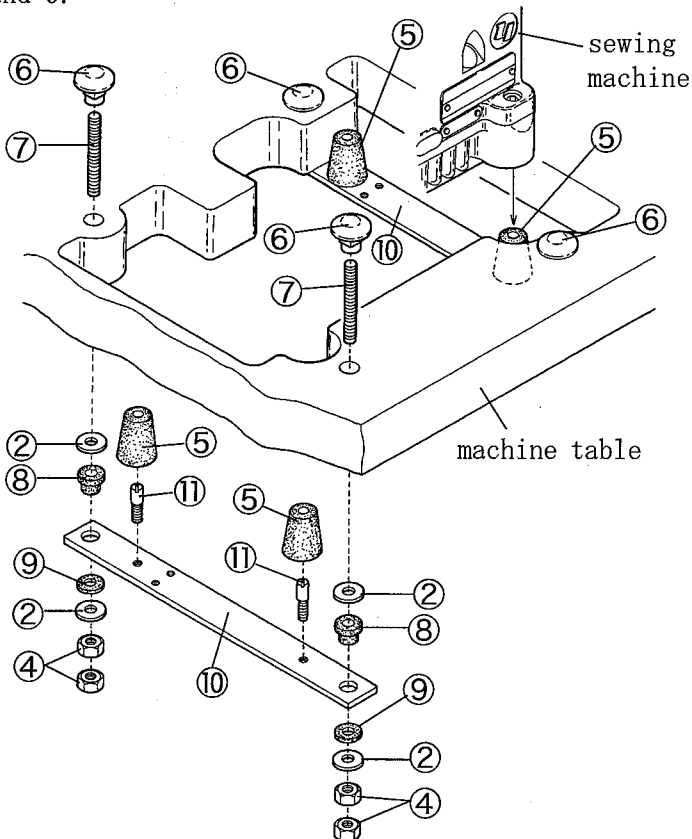

Fig. 8

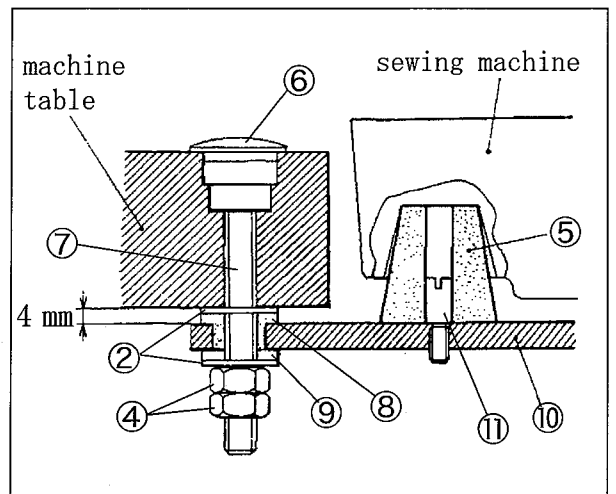

Fig. 9

## 2.4 Motor and belt

See the instruction manual for the motor used and install the motor properly.

To install the clutch motor, align the center of the machine pulley with that of the motor pulley when the motor pulley shifts to the left with toeing down the pedal.

Note: Table 1 shows the outside diameter of the motor pulley, rpm of the machine, and size of the belt when using the clutch motor of 3-phase, 2-pole, 400W(1/2HP).

The outside diameter on the table shows the nearest size to the calculated values based on the commercial available pulleys at intervals of 5 mm.

### ⚠ CAUTION

Use only those motor pulleys applicable to the machine. If not, the sewing speed will be over maximum and it can cause the damage to the machine.

## 2.5 Hanging belt

### ⚠ WARNING

Before hanging belt, ALWAYS turn the power switch OFF and check that the machine has already stopped.

Use the M-type of V-belt.

- (1) Hang the belt ① on the machine pulley ②, and then on the motor pulley ③ while rotating the machine pulley.
- (2) Adjust the belt tension so that the belt has 10 - 20 mm slack when its center is pushed with 10N(1.02kgf).
- (3) Lock the motor with the nut ④.

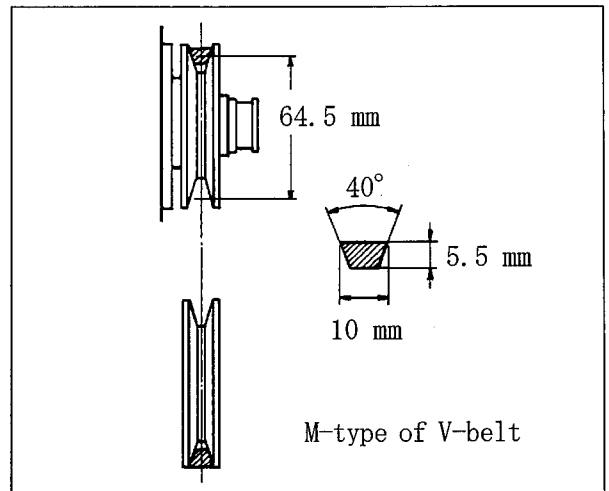

Fig. 10

Outside diameter of pulley (mm)	rpm of machine (rpm)	
	50H z	60H z
90		4500
100		5000
105	4500	
110		5500
120	5000	
125		
130	5500	

Table 1

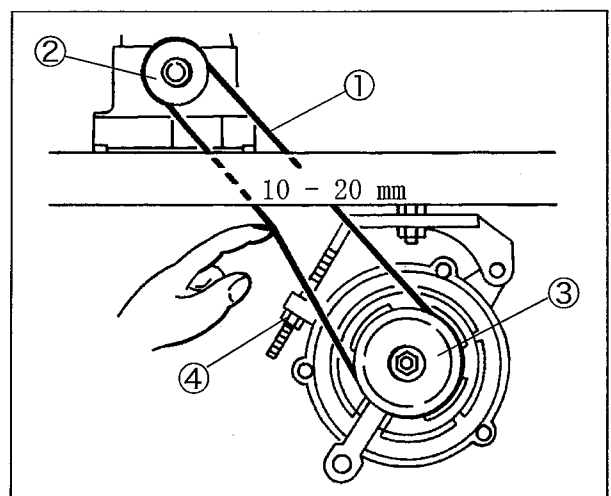

Fig. 11

### 2.6 Belt cover

#### WARNING

Be sure to install belt cover to prevent you from injuring and a material from being caught by the belt.

- (1) Install the belt cover ①. (See Fig. 12)
- (2) Push the belt cover support ② to the belt cover ① to install it.
- (3) Fix the belt cover(lower) ③ on the machine table only for table top type. (See Fig. 14)

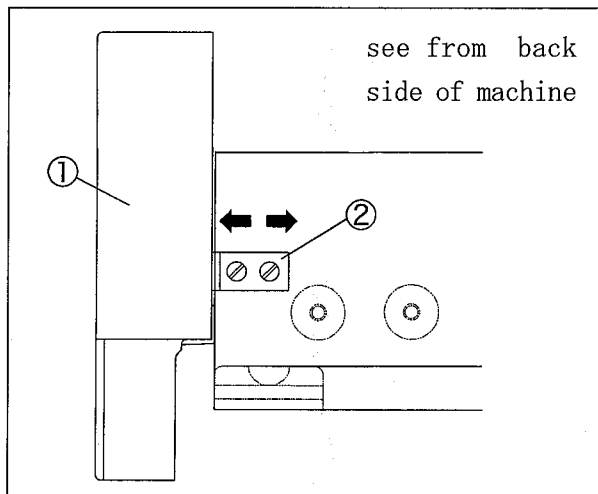

Fig. 13

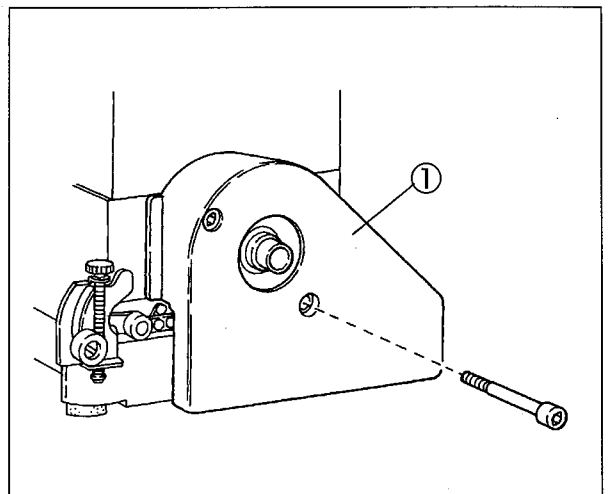

Fig. 12

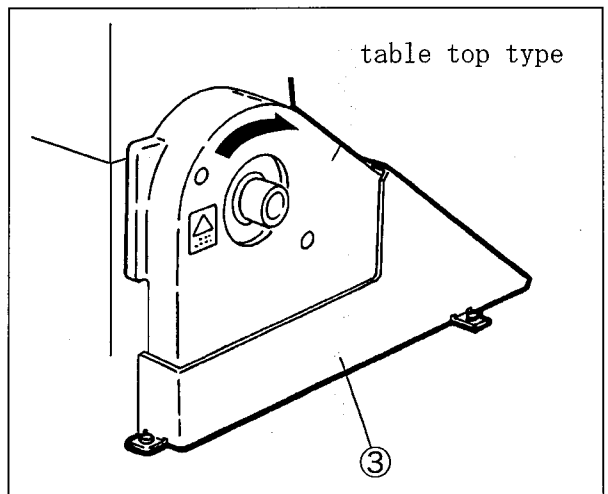

Fig. 14

### 2.7 Eye guard and finger guard

To ensure safe use, always install the eye guard ④ and the finger guard ⑤ on the prescribed position when operating.

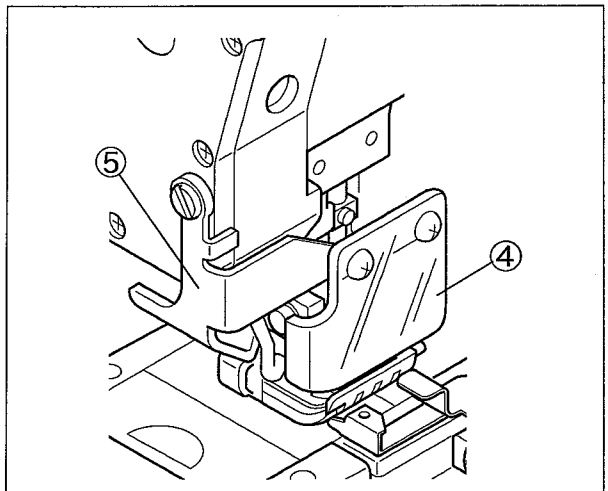

Fig. 15

# 3. Sewing speed and rotating direction of pulley

The maximum sewing speed is 5500 rpm (during intermittent operation).

Run a new machine at 4500 rpm during the first 200 hours (for about one month) so that the machine can offer a long service life in good condition.

The rotating directions of the machine pulley① and the handwheel② are clockwise as shown in the figure.

## ⚠ CAUTION

If rotating in reverse direction, oil cannot be supplied properly. It can cause the damage to the machine.

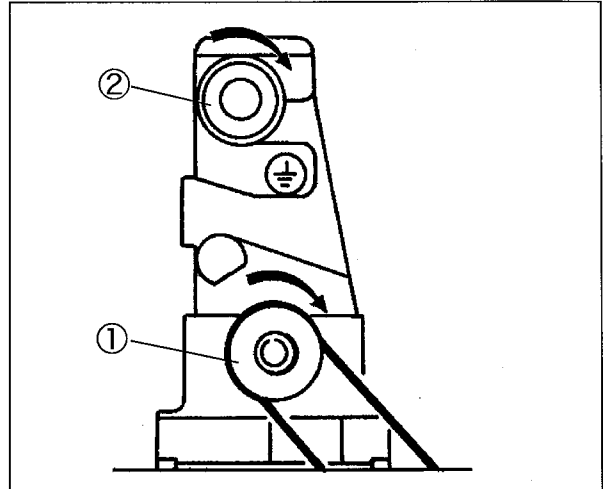

Fig. 16



# 4. Lubrication

## ⚠ WARNING

Before lubricating, ALWAYS turn the power switch OFF and check that the machine has already stopped.

### 4.1 Lubricating oil

Use YAMATO SF OIL No. 28.

## ⚠ CAUTION

Never add additives to the oil.  
If added, it can cause the deterioration of the oil and the damage to the machine.

### 4.2 Lubricating

When using a new machine, or a machine which has not been run for a while, supply with a few drops of oil to the needle bar ① and the looper bar ②.

Remove the seal plug ③ indicated "OIL" and supply with oil to the upper line of the oil sight gauge ④.

Check that oil splashes from the nozzle inside the oil sight window ⑤ with running the machine.

If oil does not splash from the nozzle, see "4.4 Checking and replacing oil filter" on page 11.

## ⚠ CAUTION

Too much or insufficient oil can cause oil leakage and machine trouble. Be sure to keep the oil level between the lines. Also too much lubrication can cause oil scatter and material stain.

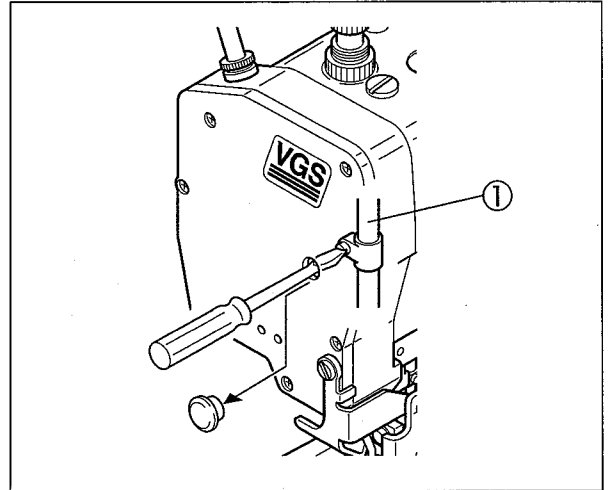

Fig. 17

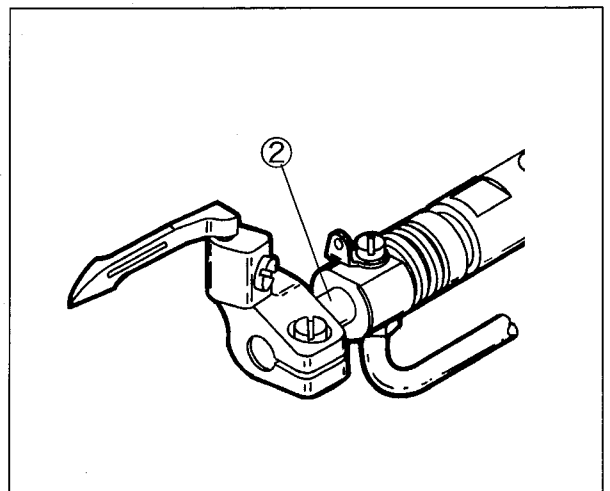

Fig. 18

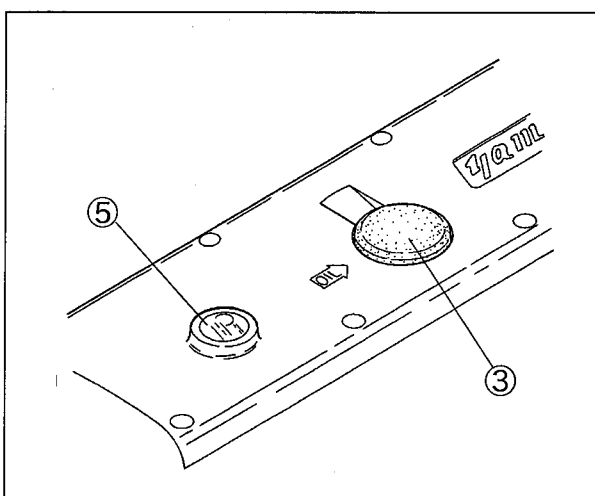

Fig. 19

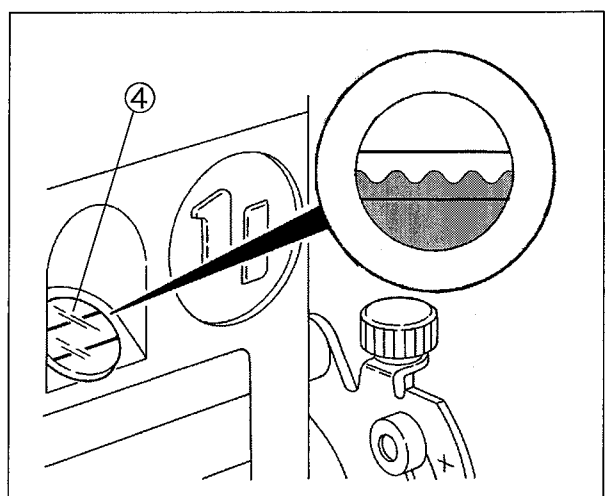

Fig. 20

## ⚠ WARNING

Before lubricating, ALWAYS turn the power switch OFF and check that the machine has already stopped.

### 4.3 Changing oil

#### Period of changing:

When using a new machine, change the lubricating oil after running a machine for 250 hours (for about one month). After that, change the oil once or twice a year.

#### Procedure for changing:

- (1) Remove the belt cover. (See page 8)
- (2) Remove V-belt from the motor pulley. (See page 7)
- (3) Remove the machine from the machine table.
- (4) Set a container received the oil under the screw ①.
- (5) After removing screw ①, the oil is drained.

### NOTE

**Be careful not to soil the V-belt and the machine pulley with the oil.**

- (6) Reset the screw ①.
- (7) Change the oil. (See "4.2 lubricating" on page 10)
- (8) Reset the machine on the machine table.
- (9) Hang V-belt on the motor pulley and reset the belt cover. (See pages 7 and 8)

### 4.4 Checking and replacing oil filter

- ◆ If the oil filter ② is clogged with dust, lubrication cannot be done properly.
- ◆ Remove the oil filter cap ③ and the oil filter ② to check them every six months. If clogged or cracked, clean or replace the oil filter.
- ◆ If oil is splashed from the nozzle insufficiently or includes many bubbles though the oil is sufficiently kept, check or replace the oil filter.

### NOTE

**Carefully check and replace them without spilling oil stagnant in the oil filter ② when loosening screw ④.**

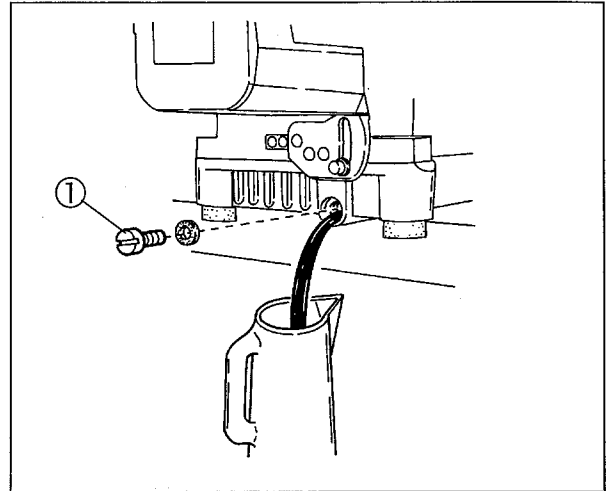

Fig. 21

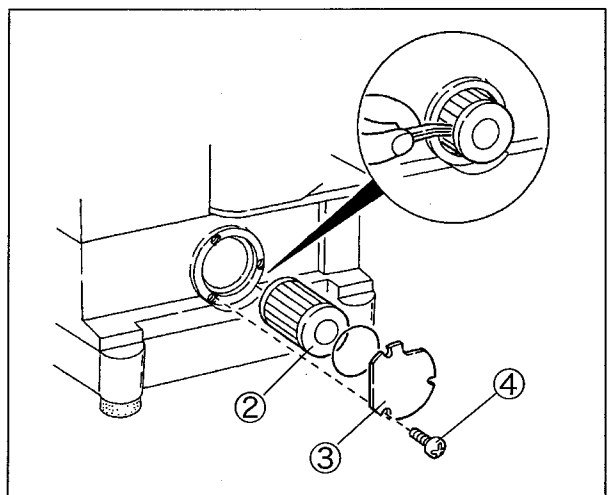

Fig. 22

# 5. Proper operation

## 5.1 Needle system

Use UY × 128GAS (UY128GAS).

Select a proper needle in size depending on the thickness and type of fabric.

Japanese standard	9	10	11	12	13	14
Metric standard	65	70	75	80	85	90

Table 2

## 5.2 Installing needles



### WARNING

Before installing, ALWAYS turn the power switch OFF and check that the machine has already stopped.

- (1) Loosen the screws① with a screwdriver. (Fig. 23)
- (2) Remove an old needle with a pair of tweezers.
- (3) Insert a new needle into the needle clamp② as far as it will go with facing its scarf to the right back. (Figs. 24 and 25)
- (4) Tighten the screws① with a screwdriver

### NOTE

Tighten the screws① with a tightening torque of 0.6N·m(6kgf·cm).

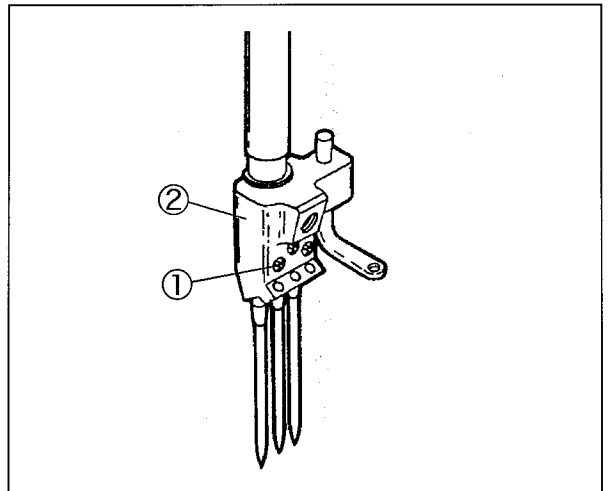

Fig. 23

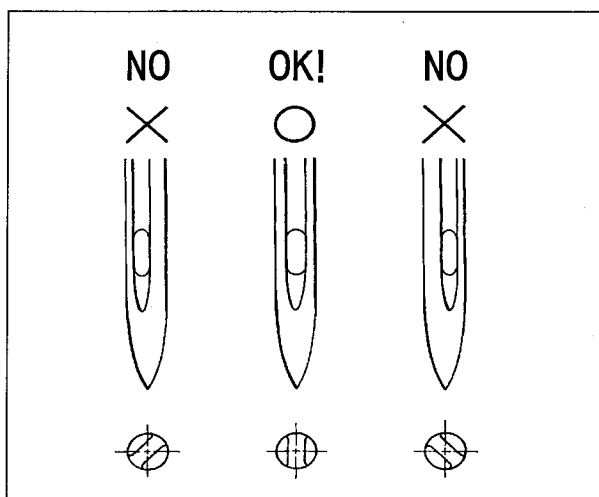

Fig. 24

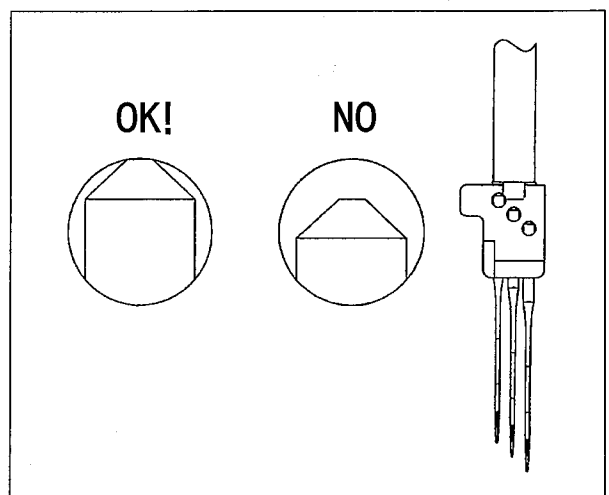

Fig. 25

## 5.3 Threading



When not threaded, thread correctly as shown in Fig. 26.

When threaded, rethread after knotting preset threads.

### ☆ Needle thread

Pull out the thread until it is in front of the needle. Then, cut off the knot before needle eye to rethread.

Thread correctly for the left needle in the inmost position as shown in the figure.

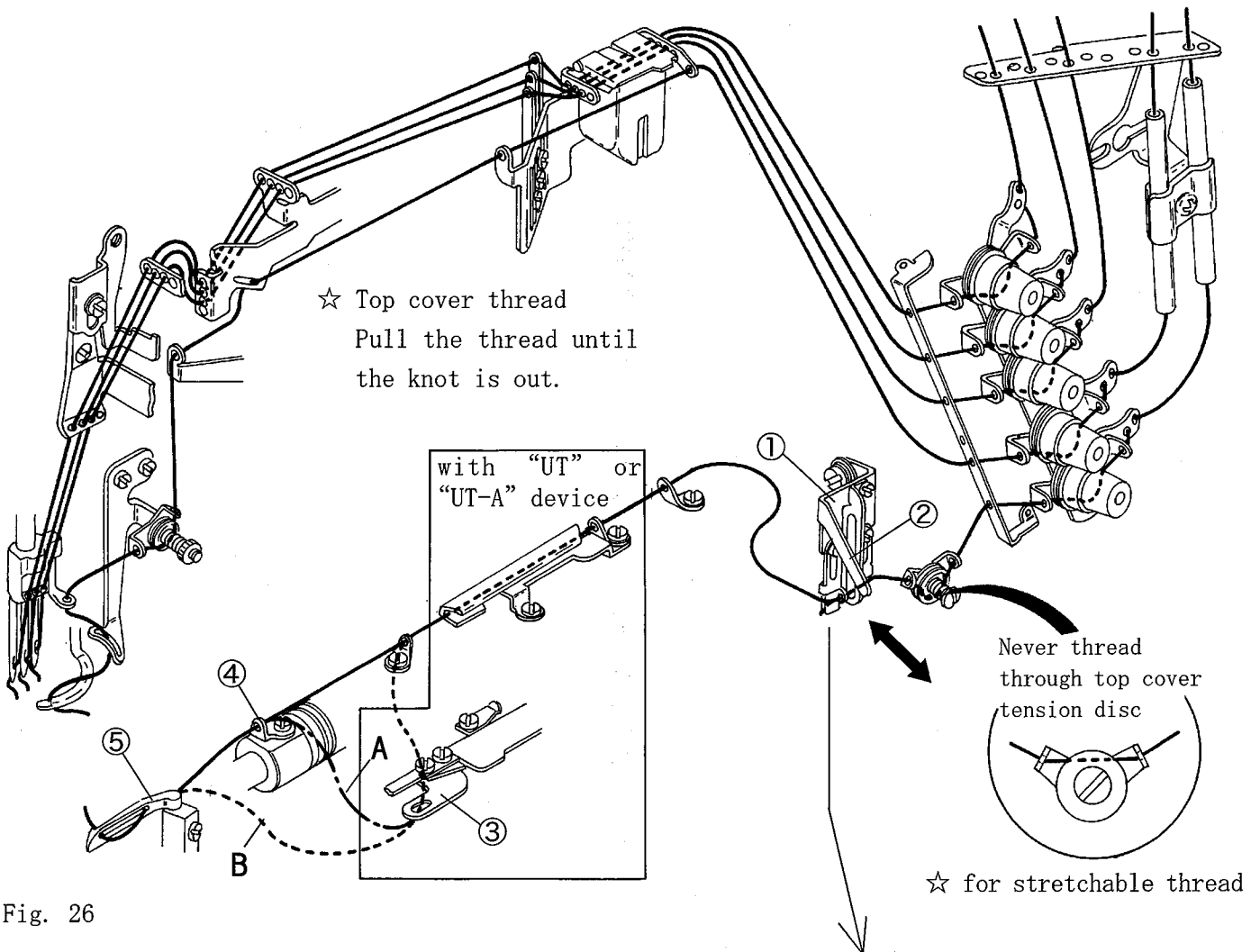

Fig. 26

### ☆ Looper thread

Pull the thread until the knot is out.

Then, cut off the knot.

Note: Threading for sewing with "UT" or "UT-A" device

\* For standard type of thread, thread through the looper thread eyelet (left) ④ via the looper thread release ③. (Thread A)

\* For cotton thread or polyester thread, thread directly through the looper ⑤ via the looper thread release ③. (Thread B)

Note: For easy threading, pull the lever ② of the thread take-up eyelet holder ①.

After threading, push the lever ② to reset the thread take-up eyelet holder ① to the original position.

## 5. Proper operation

### 5.4 Adjusting thread tension



Adjust the thread tension with the thread tension spring caps ① depending on fabric type, thread type, seam width, stitch length, and other sewing conditions.

- To tighten the thread tension, turn the caps clockwise.
- To loosen the thread tension, turn the caps counterclockwise.

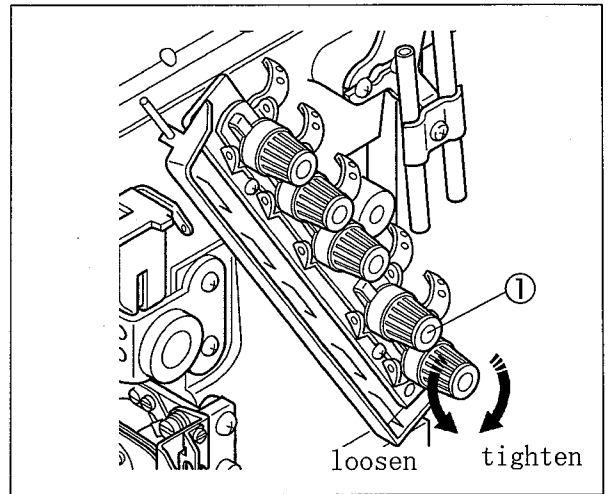

Fig. 27

### 5.5 Pressure of presser foot



Loosen the lock nut ② and turn the presser spring regulator ③ to adjust the pressure.

- To increase the pressure, turn it clockwise.
- To decrease the pressure, turn it counterclockwise.

Keep the pressure to a minimum for stable sewing performance.

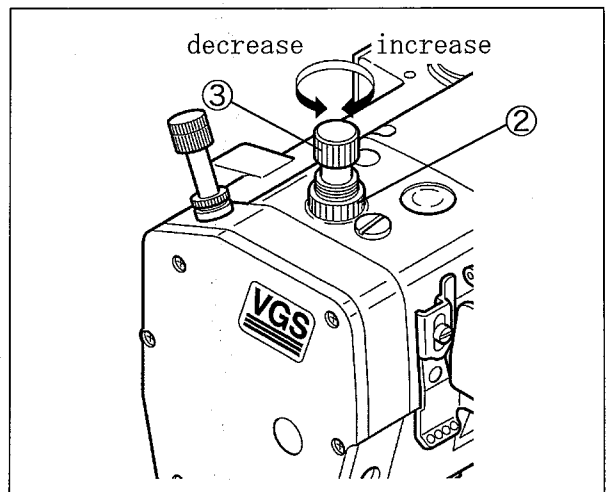

Fig. 28

### 5.6 Adjusting position of presser foot

#### WARNING

Before adjusting, ALWAYS turn the power switch OFF and check that the machine has already stopped.

Adjust left-and-right position of the needle holes of the presser foot.

Loosen the screw ④. Move the front of the presser foot right or left so that the needle drops in the center of the needle drop.

Then, tighten the screw ④ securely.

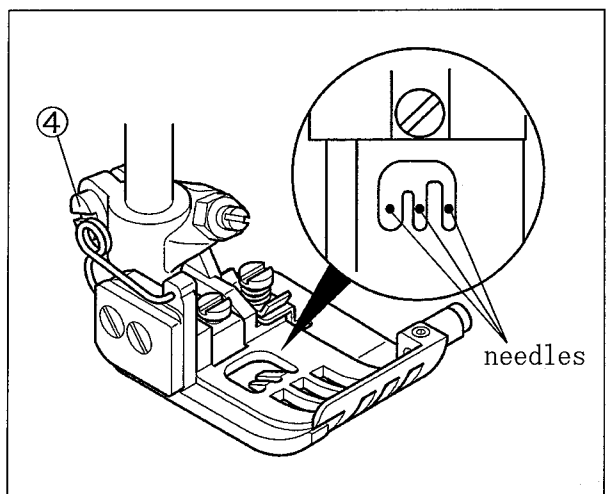

Fig. 29

## ⚠ WARNING

Before operating, ALWAYS turn the power switch OFF and check that the machine has already stopped.

### 5.7 Adjusting movement of differential feed dog



The differential ratio has been set from 1:0.9 to 1:1.4 at shipment.

When aligned the differential feed lever (right) ① with the line ② of the differential feed graduations, the movement of the differential feed dog is the same as that of the main feed dog (differential ratio 1:1), resulting in uniform sewing.

- (1) Loosen the lock nut ③.
- (2) Turn the adjusting screw ④ to adjust the movement of the differential feed dog.
  - To increase the movement for gathering, turn it clockwise.
  - To decrease the movement for stretching, turn it counterclockwise.
- (3) Tighten the lock nut ③ securely.

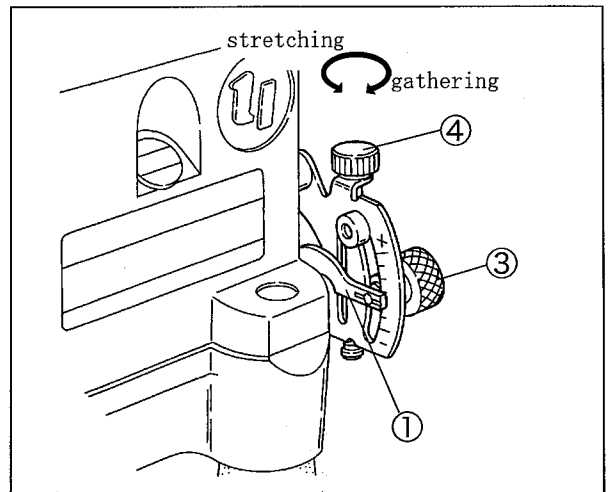

Fig. 30

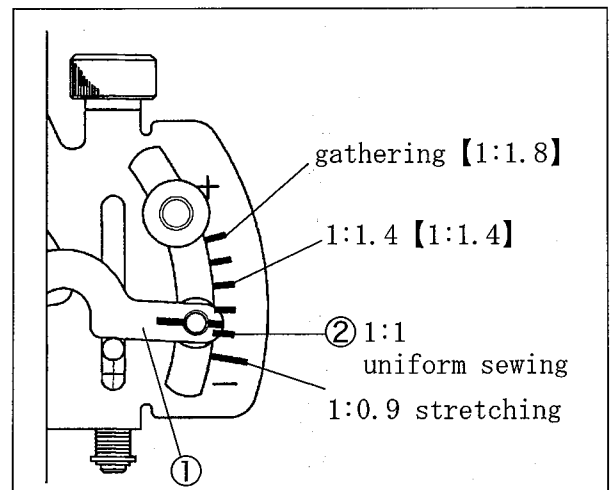

Fig. 31

## 5. Proper operation

### 5.8 Adjusting stitch length



Stitch length is adjustable from 1.4 to 3.6 mm. Table 3 shows the number of stitches per inch (25.4 mm) and 30 mm converted to the stitch length.

The main feed lever stopper<sup>⑤</sup> has been adjusted so as to stop at maximum 3.6 mm with the screw<sup>⑥</sup> at shipment.

#### Adjusting procedure:

- (1) Loosen the lock nut<sup>①</sup>.
- (2) Align the end of the main feed lever<sup>④</sup> with the required position on the main feed graduations<sup>③</sup>. Turn the main feed bar adjusting screw<sup>②</sup> to adjust it.

- To make the stitch length smaller, turn it clockwise.
- To make the stitch length larger, turn it counterclockwise.

Stitch length (mm)	Number of stitch (per 1 inch)	Number of stitch (per 30 mm)
1.4	18	21
2.0	13	15
3.0	8.5	10
3.6	7	8

Table 3

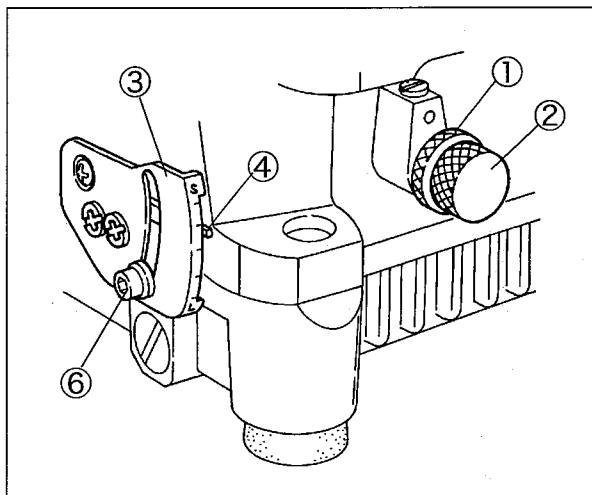

Fig. 32

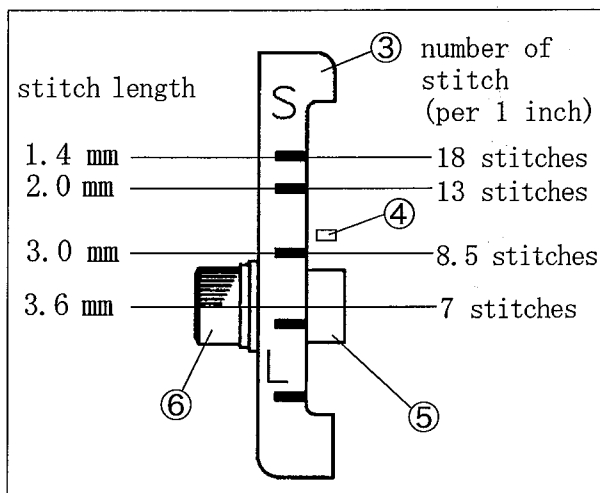

Fig. 33

## ⚠ WARNING

Before operating, ALWAYS turn the power switch OFF and check that the machine has already stopped.

### 5.9 Adjusting feeding amount of top feed dog (stitch length) to lower feed dog

The top and the lower feed dogs drive independently. Adjust the top feeding amount after changing the lower feeding amount.

The standard ratio of top feeding to lower feeding is 1:1.

Note: The mark shows stitch length of the top feed graduation ① as below.

S: 1.6 mm

L: 7.0 mm

Turn the adjusting screw ② to adjust it.

- To increase the feeding amount, turn it clockwise.
- To decrease the feeding amount, turn it counter-clockwise.

## ⚠ CAUTION

Run a machine at 5000 rpm or less when feeding amount of top feed dog is 6.0 - 7.0 mm.

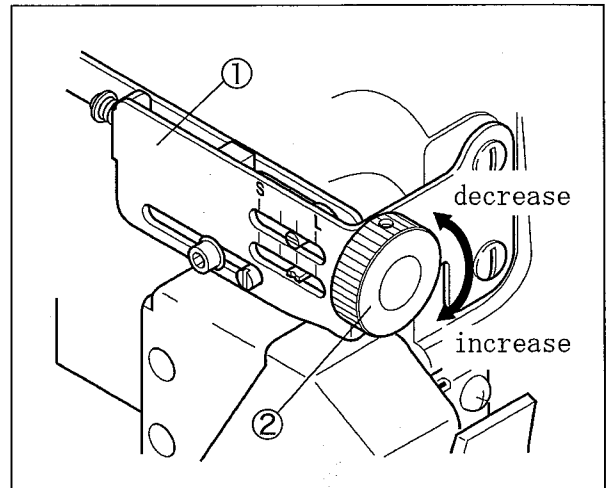

Fig. 34

### 5.10 Position of folder

- (1) Loosen the screws ③ of the folder.
- (2) Align the folders(right) ④ and (left) ⑤ with the fabric end with hem width.
- (3) Tighten the screws ③ securely.

\* Use the folder chip ⑥ for light weight fabric.  
Fix it with the screw ⑦.

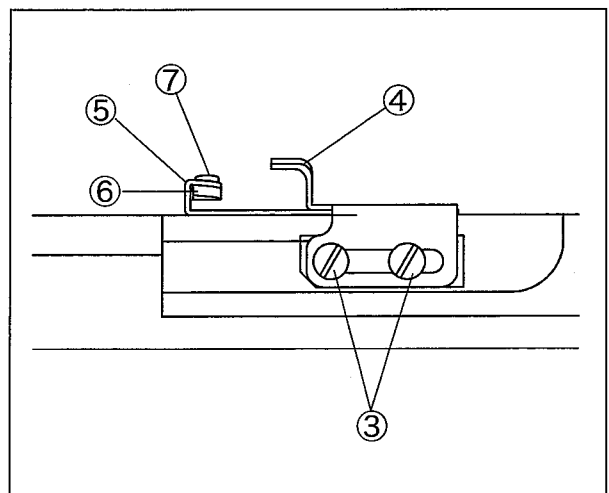

Fig. 35



## 5. Proper operation

### WARNING

Before operating, ALWAYS turn the power switch OFF and check that the machine has already stopped.

### 5.11 SP device and HR device

Use SP device (needle thread oiling) equipped as standard to prevent thread breakage and skip stitch when running a machine at high speed or using synthetic thread and/or synthetic fabric.

Also use HR device (needle point cooling) as an extra.

Use dimethyl silicon oil.

Open the lid① of SP container and the lid② of HR container to check the oil level.

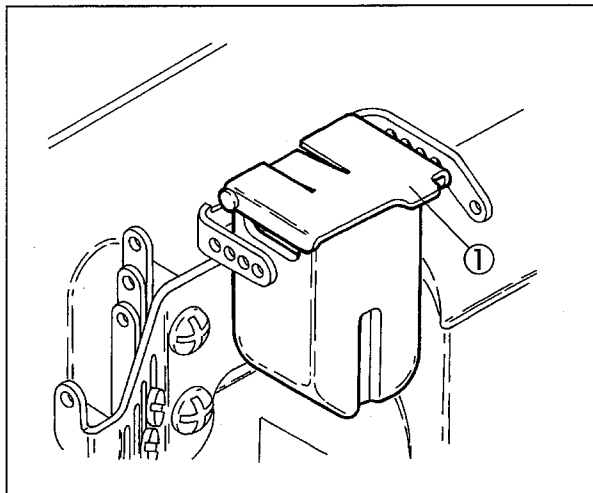

Fig. 36

### CAUTION

1. When not using SP device and HR device, remove the felt③. If not removed, it may occur irregular condition during sewing.
2. If silicone oil is stucked to the parts other than SP and HR devices, it can cause the machine trouble. Be sure to wipe it away.

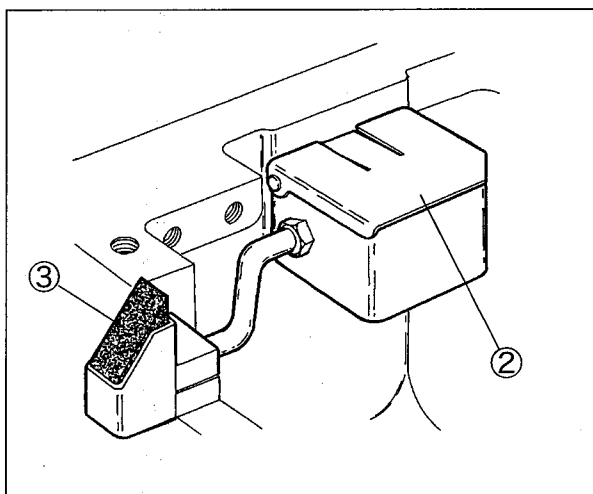

Fig. 37

### 5.12 Cleaning the machine

Clean waste thread and dust inside the machine at the end of work a day.

Remove the seal plug④ at the back of the machine and clean the grooves in the stitch plate, feed dog area, and oil filter screen area once a week.

### NOTE

If the oil filter screen is clogged with dust, oil in the cylinder does not return to the oil reservoir. It can cause oil leakage.

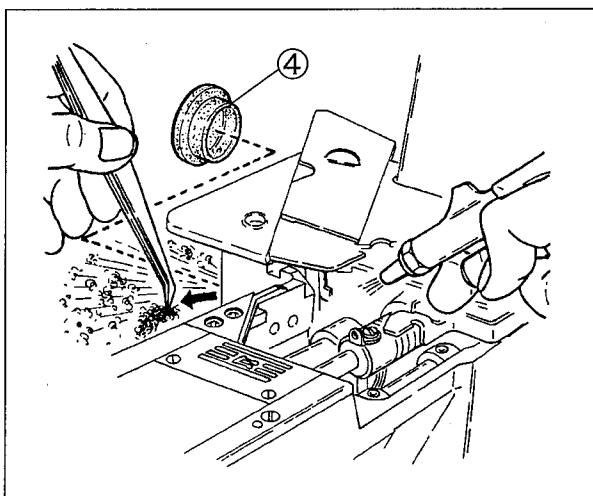

Fig. 38

# 6. Adjustments

## WARNING

Before adjusting, ALWAYS turn the power switch OFF and check that the machine has already stopped.

### 6.1 Needle thread tension

#### Needle thread eyelet:

As standard, align the center of the screw with the line of the needle thread eyelet bracket④ as below.

Right needle thread eyelet① : top line  
Middle needle thread eyelet② : middle line  
Left needle thread eyelet③ : bottom line

- To loosen the needle thread tension, lower the needle thread eyelet.
- To tighten the needle thread tension, raise the needle thread eyelet.

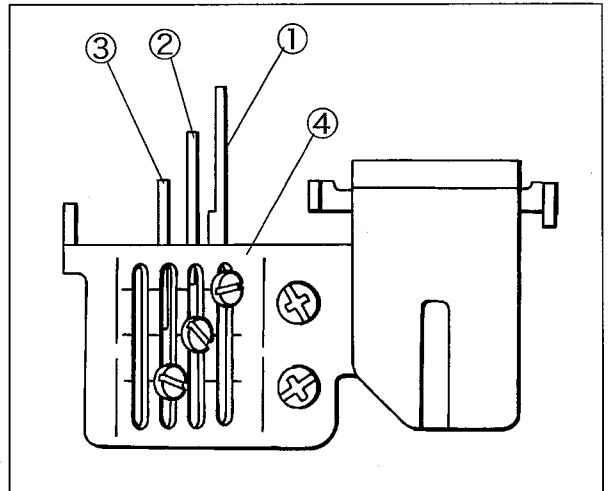

Fig. 39

#### Needle thread guide:

Make a distance between the center of the eye in the needle thread take-up⑥ and the top of the needle thread guide⑤ to 4.0 mm when the needle thread take-up⑥ is at the lowest point as standard.

Loosen the screw⑦ to adjust it.

- To make the needle thread loop larger or when using stretchable thread, raise the needle thread guide⑤.
- To make the loop smaller, lower the needle thread guide⑤.

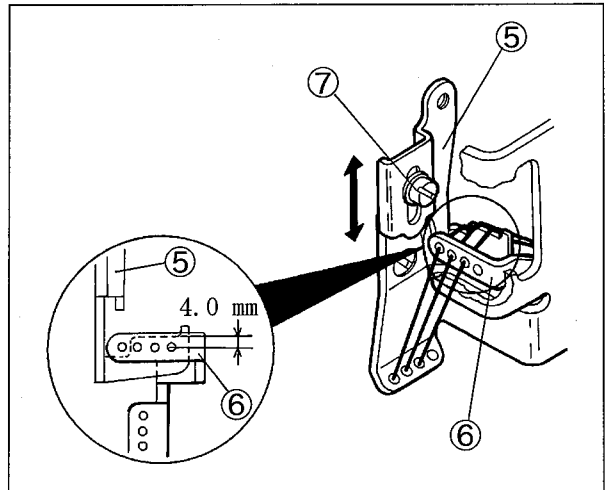

Fig. 40

## 6. Adjustments

### 6.2 Top cover thread tension

Align the center of the slot of the top cover thread eyelet(upper)① with the center of the screw ② as standard.

Loosen the screws ② and ③ to adjust it.

- To increase the feeding amount, raise the top cover thread eyelet(upper)①.
- To decrease the feeding amount, lower the top cover thread eyelet(upper)①.

#### NOTE

When using stretchable thread like woolly, adjust the top cover thread eyelet(upper)① higher than standard.

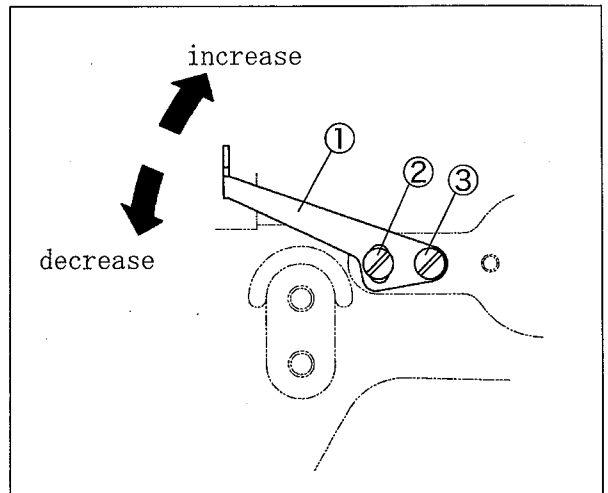

Fig . 41

### 6.3 Looper thread tension

Align the eyes of the thread take-up eyelets(left) ⑤ and (right)⑥ 3.0 mm under the lines ④ on the thread take-up eyelet holder as standard.

Loosen the screws of both thread take-up eyelets to adjust them.

- To tighten the looper thread tension, raise both eyelets.
- To loosen the looper thread tension, lower both eyelets.

#### NOTE

When using stretchable thread, move the thread take-up eyelets ⑤ and ⑥ at the lowest points. Do not thread through the top cover tension disc ⑦.

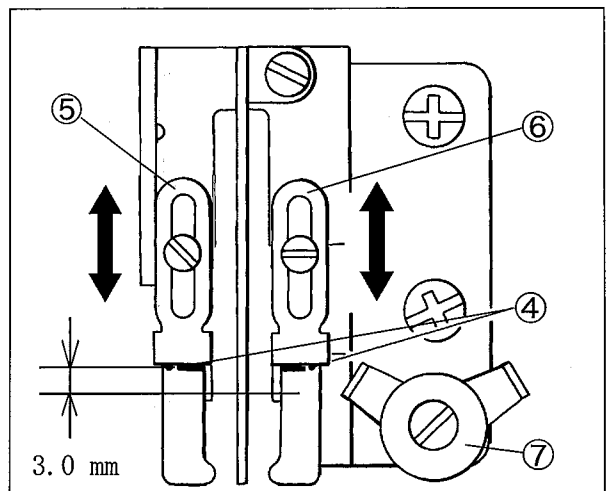

Fig. 42

## 6.4 Needle and spreader

### 6.4.1 Spreader

- (1) Loosen the screws ③ and ④ of the spreader holder. (Fig. 45)
- (2) Make a clearance between the left needle and the hook ② of the spreader ① to 0.5 - 0.8 mm. (Fig. 43)
- (3) Make a clearance between the center of the left needle and the hook ② to 4.5 - 5.5 mm when the spreader ① is at the extreme left. Then tighten the screw ④ securely. (Figs. 43 and 45)
- (4) Make a height from the top of the stitch plate to the bottom of the spreader ① to 8.5 - 9.5 mm. Then tighten the screw ③ securely. (Figs. 44 and 45)

### NOTE

Adjust a height of the spreader so that the top cover thread passes behind the right needle and be caught by the left needle within adjustable range based on the needle distance.

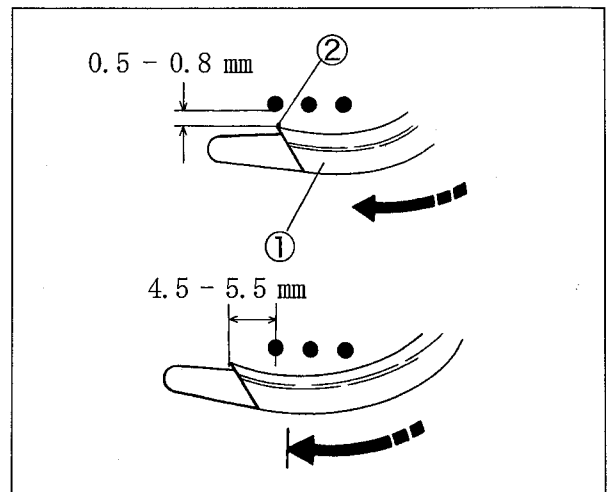

Fig. 43

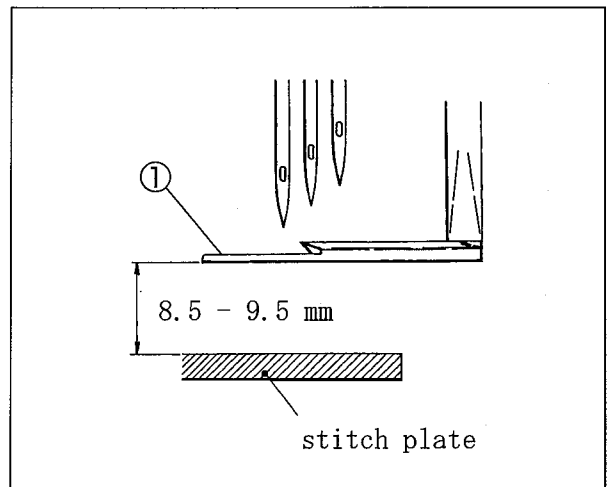

Fig. 44

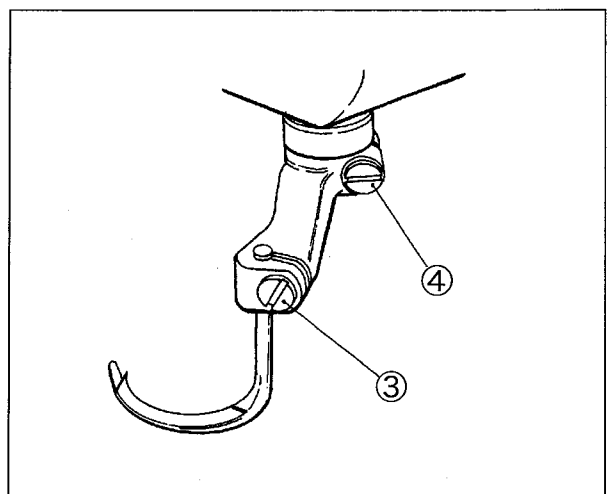

Fig. 45

## 6. Adjustments

### 6.4.2 Top cover thread guide

- (1) Loosen the screws ② of the top cover thread guide ①. (Fig. 46)
- (2) Make a clearance between the top of the spreader ③ and the bottom of the top cover thread guide ① to 0.5 mm. (Fig. 46)
- (3) Set the hook ④ in the center of the slot of the top cover thread guide ① when the spreader ③ is at the extreme right. Then, tighten the screws ② securely. (Figs. 46 and 47)

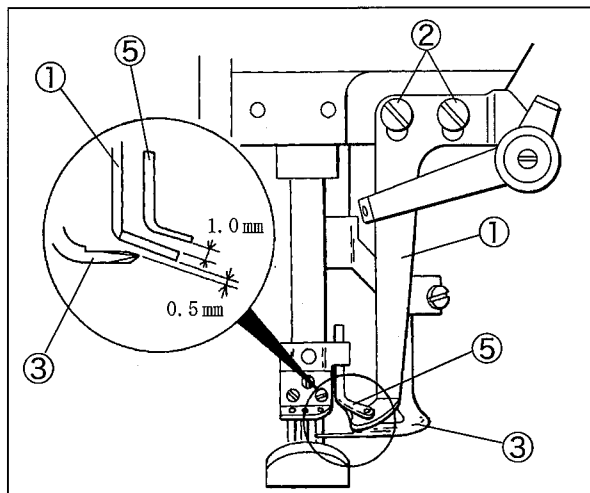

Fig. 46

### 6.4.3 Top cover thread eyelet

- (1) Loosen the screw ⑥ of the top cover thread eyelet ⑤. (Fig. 47)
- (2) Make a clearance between the top of the top cover thread guide ① and the top cover thread eyelet ⑤ to 1.0 mm when the needle bar is at the lowest point. (Fig. 46)
- (3) Set the eye of the top cover thread eyelet ⑤ along the extending line from the slot of the top cover thread guide ①. (Fig. 47)
- (4) Tighten the screw ⑥ securely. (Fig. 47)

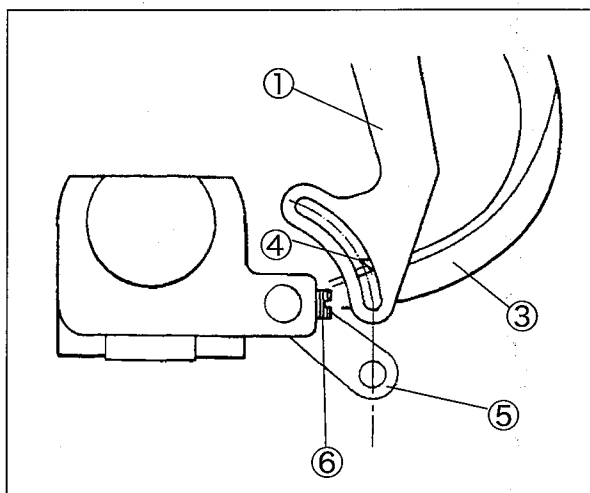

Fig. 47

## 6.5 Distance between needle and looper

A distance between the looper tip and the center of the right needle depends on the needle distance when the needles are at the lowest points and the looper ① is at the extreme right.

See Table 4 and loosen the screw ② of the looper holder to adjust the distance.

### NOTE

A distance between the center of the needle bar and the looper ① tip is 6.0 mm even if the needle distance changes.

needle distance (mark)	gauge mark	looper's distance
3.2 mm (32)	A	4.4 mm
4.0 " (40)	B	4.0 "
4.8 " (48)	C	3.6 "
5.6 " (56)	D	3.2 "
6.4 " (64)	E	2.8 "

Table 4

The timing gauge (No. 95220) makes it possible to adjust a distance easily.

A timing gauge is an extra part. Place an order with our agents or directly with us, if needed.

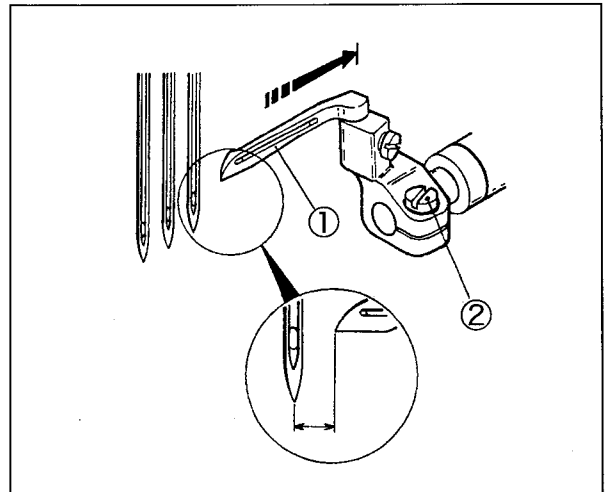

Fig. 48

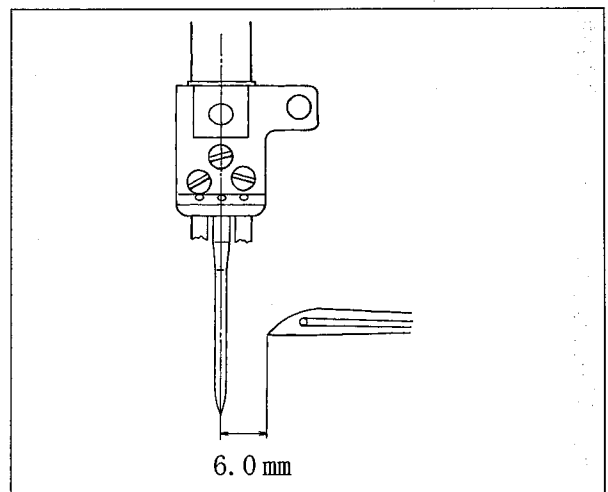

Fig. 49

## 6.6 Using timing gauge

A timing gauge has the marks (A, B, C, D, E) for each needle distance.

Move the looper at the extreme right. Keep fitting the right needle into the groove "V" corresponding needle distance, and fit the looper tip to the gauge.

Then, tighten the screw ② securely.

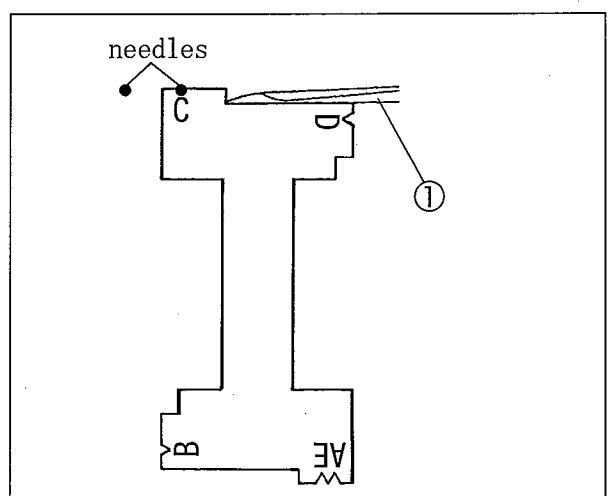

Fig. 50

## 6. Adjustments

### 6.7 Height of needle

- (1) Install the needle to the left hole in the needle clamp.
- (2) Check the looper is inserted into the looper holder fully.
- (3) Turn the handwheel until the looper tip meets the center of the left needle.
- (4) Loosen the screw ① of the needle bar bracket and move the needle bar up or down. Adjust the looper tip to pass 0.8 - 1.3 mm above the top of the needle eye.
- (5) Tighten the screw ① securely. Check that the needle drops in the center of the needle hole of the stitch plate.

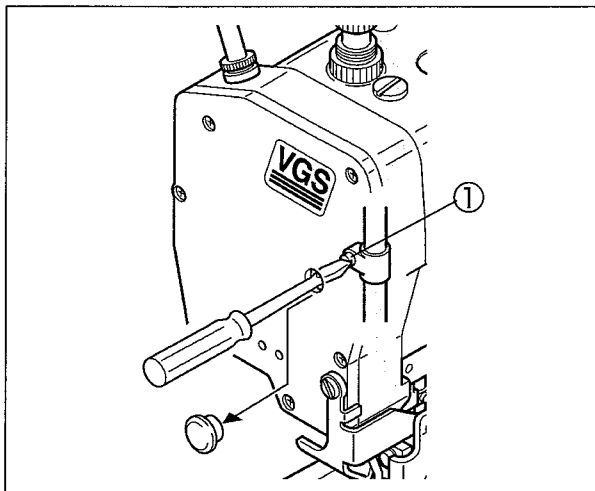

Fig. 52

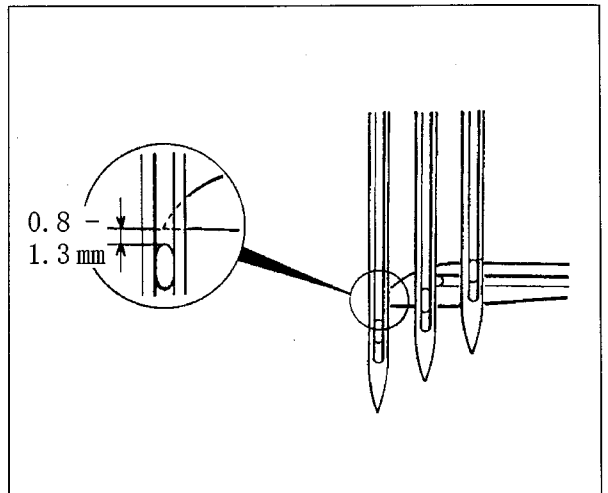

Fig. 51

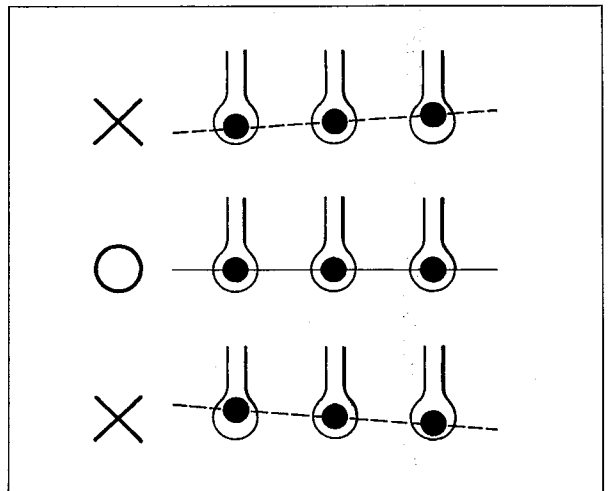

Fig. 53

### 6.8 Front-and-rear position of needle and looper

- (1) Turn the handwheel until the looper tip ④ meets the center of the left needle ⑤.
- (2) Loosen the screw ③ and move the looper holder back or forth. Make a clearance between the back of the left needle ⑤ and the looper tip to 0.2 - 0.3 mm. Then, tighten the screw ③ securely.

#### NOTE

When tightening the screw ③, front-and-rear position of the looper may be shifted. Recheck the position after tightening it.

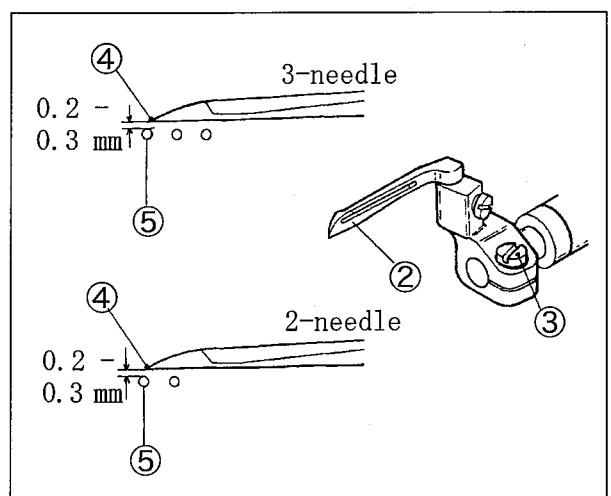

Fig. 54

## 6.9 Needle and needle guard (rear)

- (1) Turn the handwheel clockwise to lower the needles at the lowest points.
- (2) Loosen the screw ①.
- (3) Align the line ③ on the needle guard(rear) ② with the centers of the needle eyes.
- (4) Tighten the screw ① securely.
- (5) Turn the handwheel until the looper tip meets the center of the right needle.
- (6) Loosen the screws ① and ④, and move the needle guard(rear) ② back or forth. Make a clearance between the right needle and the looper tip to 0 - 0.05 mm.
- (7) Check a clearance between the left needle and the needle guard(rear) is 0 - 0.05 mm with keeping (6).
- (8) Tighten the screws ① and ④ securely.

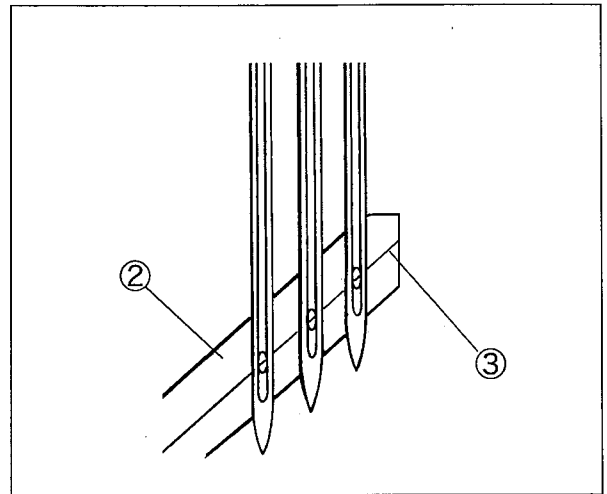

Fig. 55

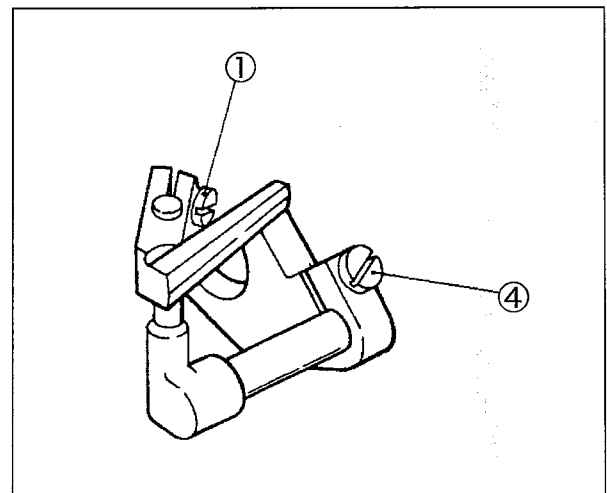

Fig. 56

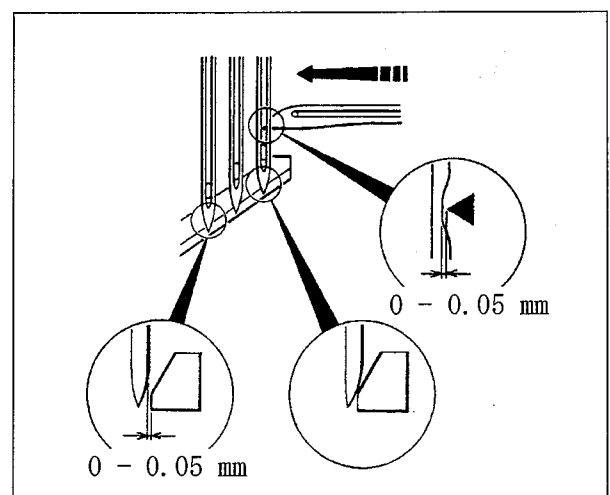

Fig. 57



## 6. Adjustments

### 6.10 Needle and needle guard (front)

- (1) Turn the handwheel clockwise until the looper tip meets the center of the left needle.
- (2) Loosen the screw ①. Adjust a height from the needle tip to the angular part of the needle guard (front) ② to 1.5 - 2.0 mm.
- (3) Tighten the screw ① securely.
- (4) Loosen the screws ① and ③. Adjust a clearance between the needle guard (front) ② and the left, or right needle to 0 - 0.3 mm respectively.
- (5) Tighten the screws ① and ③ securely.

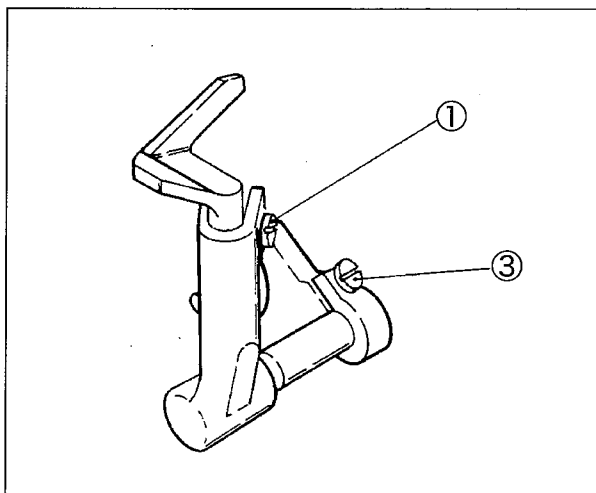

Fig. 59

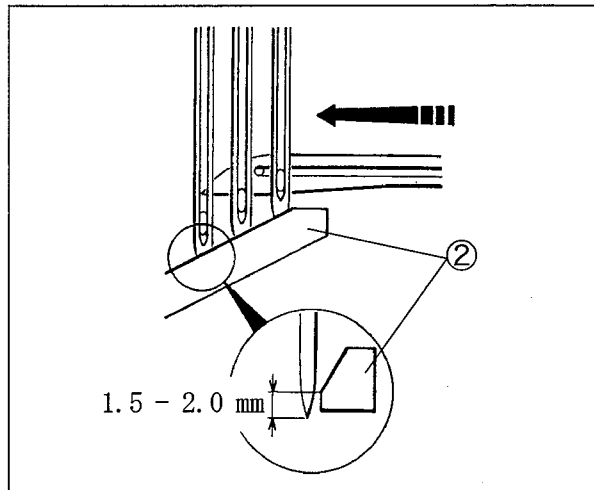

Fig. 58

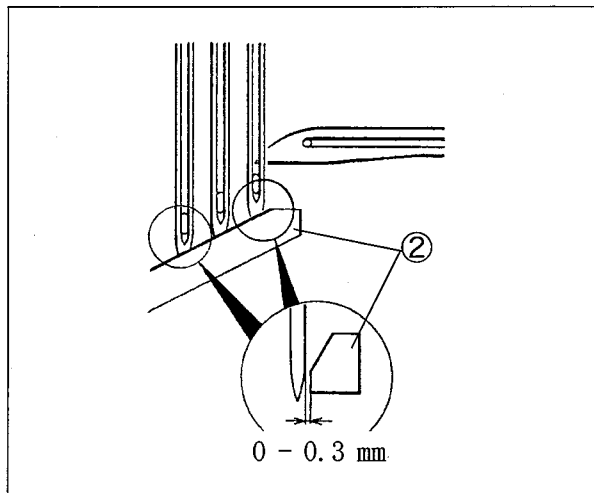

Fig. 60

### 6.11 Height of feed dog

Adjust a height from the top of the stitch plate to the tops of the differential feed dog ④ and the main feed dog ⑤ to 1.0 - 1.2 mm when the feed dogs are at the highest points as standard. Also they are parallel to the top of the stitch plate. Loosen the screws ⑥ and ⑦ to adjust them.

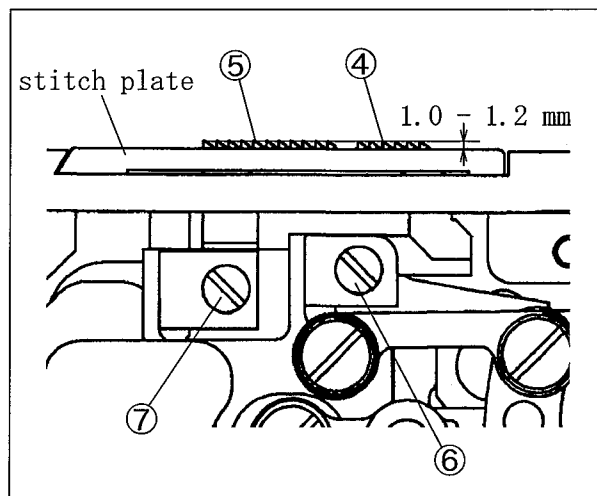

Fig. 61

## ⚠ WARNING

Before operating, ALWAYS turn the power switch OFF and check that the machine has already stopped.

### 6.12 Changing range of differential ratio

#### 6.12.1 Differential ratio 1:1.4 - 1:1.8

- (1) Adjust the stitch length to 2.5 mm or less.
- (2) Loosen the screw of the differential feed lever stopper ① and set the stopper ① to the top.
- (3) Loosen the lock nut ② and turn the adjusting screw ③ clockwise. Raise the differential feed lever (right) ④ until it touches the differential feed lever stopper ①.
- (4) Tighten the lock nut ② securely.

#### NOTE

Maximum stitch length of the main feed dog is 25 mm in a differential ratio of 1:1.8.

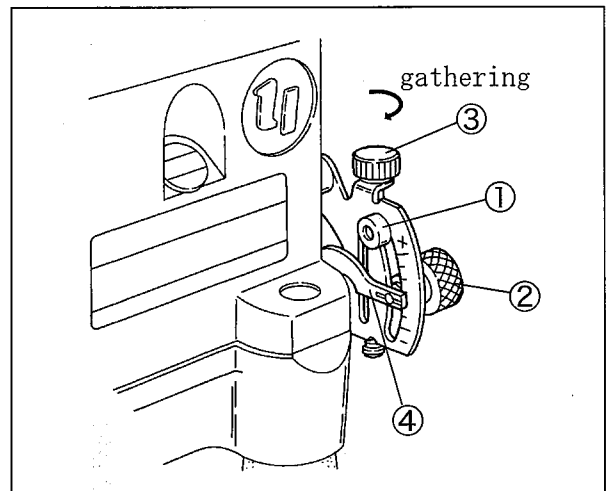

Fig. 62

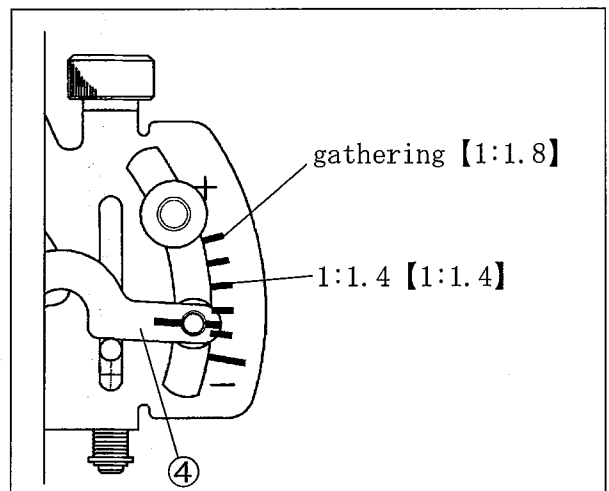

Fig. 63

## 6. Adjustments

### WARNING

Before operating, ALWAYS turn the power switch OFF and check that the machine has already stopped.

#### 6.12.2 Differential ratio 1:0.6 - 1:1.1

- (1) Remove the side cover① (three pcs. of screws).
- (2) Remove the screw③ of the differential feed bar connection②.
- (3) Fix the differential feed bar connection② in the hole④ with the screw③.

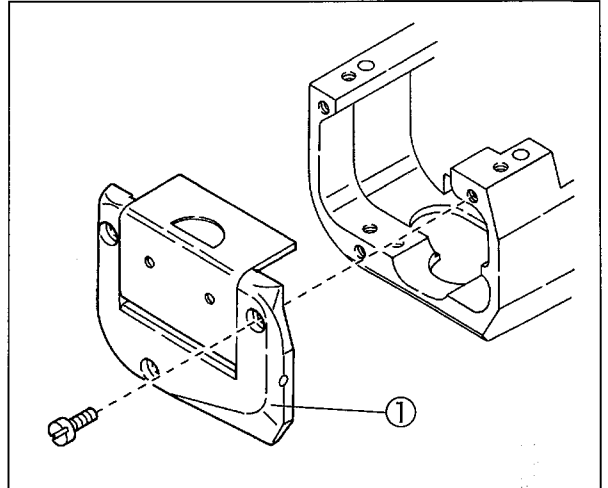

Fig. 64

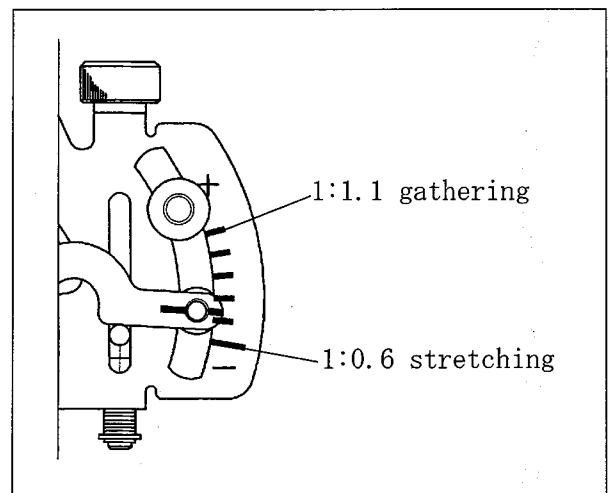

Fig. 65

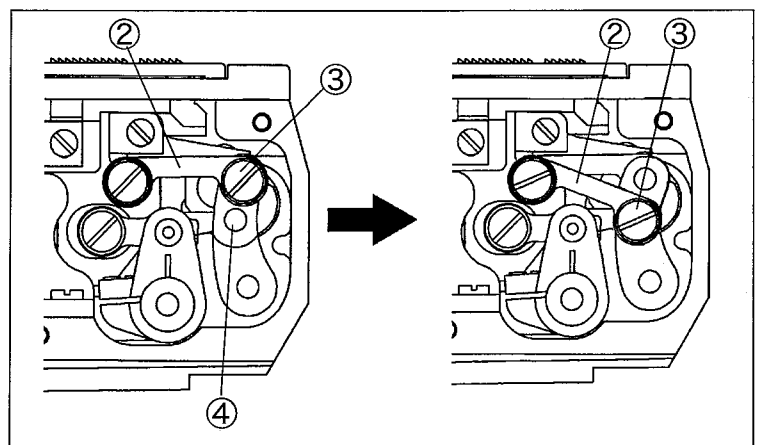

Fig. 66

## 6.13 Presser foot lift

The presser foot lift for the needle distance 5.6 mm is as follows:

- with spreader: 5.5 mm
- without spreader: 7.0 mm

- (1) Loosen the lock nut ①.
- (2) Lower the lifter lever ② to make a clearance between the top of the stitch plate and the bottom of the presser foot to 5.5 mm (7.0 mm).
- (3) Adjust the screw ③ to touch the lifter lever ② when the presser foot is raised by 5.5 mm (7.0 mm).
- (4) Tighten the lock nut ① securely.
- (5) Loosen the screws ⑤ of the collar ④.
- (6) Make a clearance between the presser bar bushing ⑥ and the collar ④ to 0.2 mm when the presser foot is raised by 5.5 mm (7.0 mm).
- (7) Tighten the screws ⑤ securely.

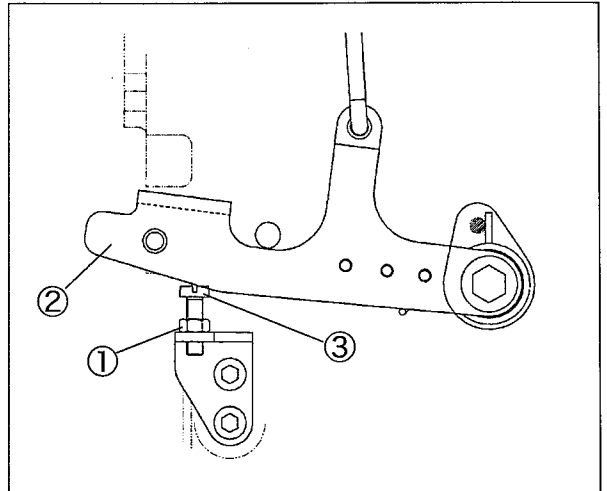

Fig. 67

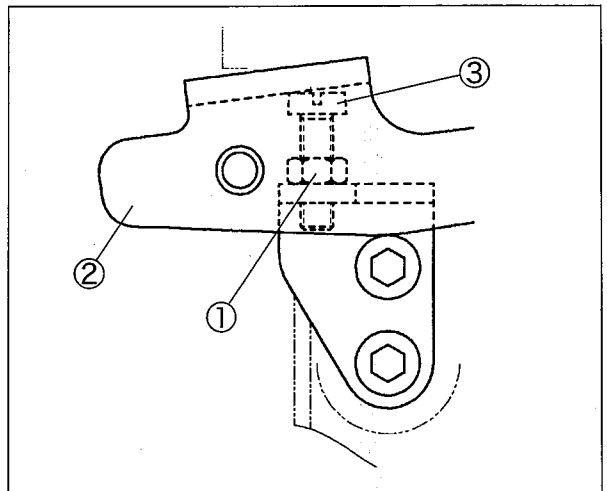

Fig. 68

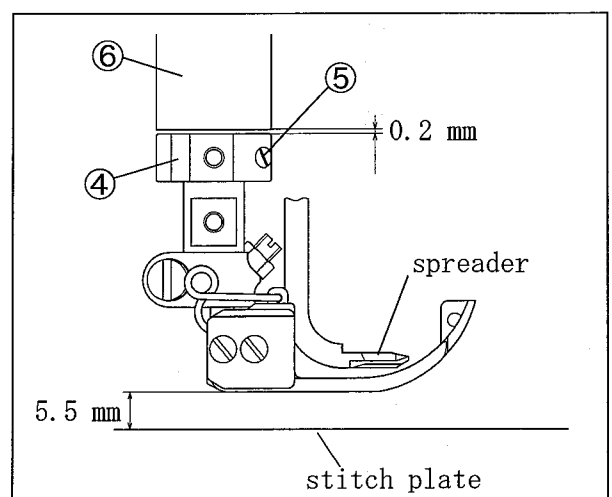

Fig. 69

## 6. Adjustments

### 6.14 Changing fabric presser

The fabric presser ② for hem width 15.9 mm (5/8 inches) has been set on the right of the presser foot ① at shipment. Also packed for 19.1 mm (3/4 inches). Use the fabric presser depending on hem width.

To remove the fabric presser ②, loosen the screw ③ of the presser foot ① and pull out the pin ④. To set it, insert it between the presser foot and the washer ⑤, fix with the pin ④, and tighten the screw ③ securely.

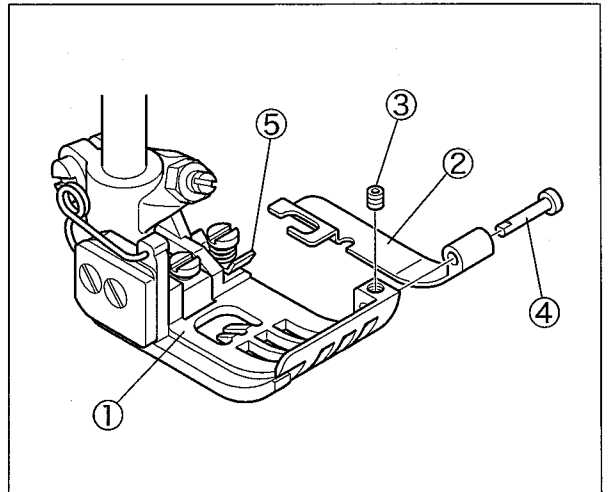

Fig. 70

### 6.15 Clearance between top and lower feed dogs

Adjusting a clearance between the top and the lower feed dogs can be obtained the stable feeding of a fabric depending on the application, type, and weight of fabric.

Adjust a clearance between the top and the lower feed dogs is as thick as one piece of a fabric at the lowest point of the top feed dog ⑥ and the highest point of the lower feed dog ⑦.

Loosen the screw ⑧ to adjust it.

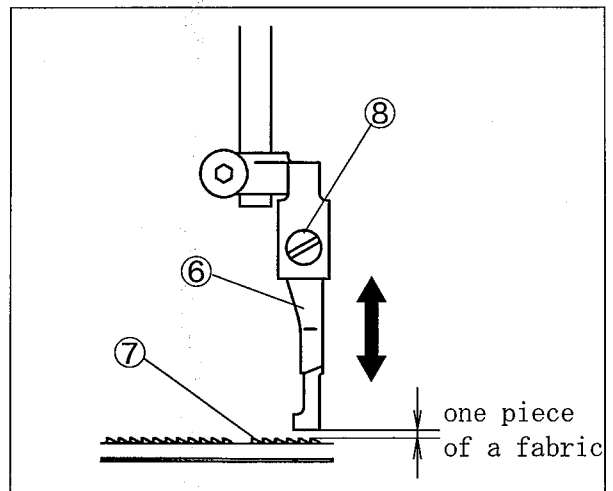

Fig. 71

### 6.16 Pressure of top feed dog

Make a distance from the end of the lock nut ⑨ to the top of the adjusting screw ⑩ to 23.0 mm as standard.

Loosen the lock nut ⑨ and turn the adjusting screw ⑩ to adjust it.

- To increase the pressure, turn it clockwise.
- To decrease the pressure, turn it counterclockwise.

Keep the pressure to a minimum for stable sewing performance.

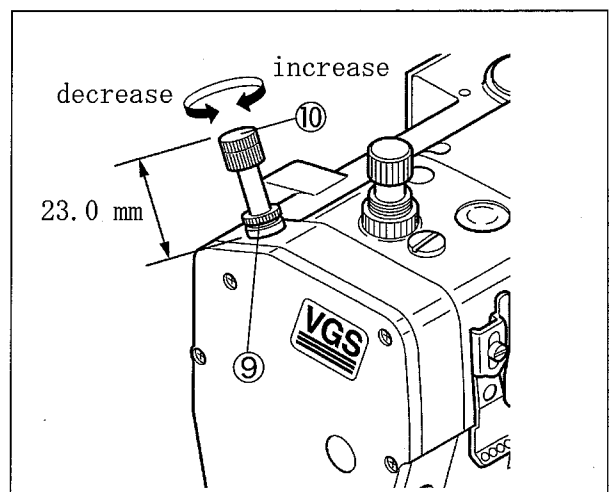

Fig. 72

# 7. Specifications

Model	VGS2700-8 class
Description	High speed cylinder bed 3-needle (2-needle) interlock stitch machine with top feeding
Dimensions	470 mm (L) × 237 mm (W) × 415 mm (H)
Circumference of Cylinder	280 mm
Weight	47.5 kg
Stitch Type	ISO 406, 407, 602, 605
Application	Plain seams, joint seams, and hemming operation for knitted fabric
Sewing Speed	Up to 5500 rpm (during intermittent operation)
Stitch Length	1.4 - 3.6 mm Number of stitches per inch (25.4 mm) 7 - 18 stitches per 30 mm 8 - 21 stitches
Needle System	UY×128GAS #9 - #14 (standard: #10)
Needle Distance	3-needle: 4.8 mm, 5.6 mm, 6.4 mm (2-needle: 3.2 mm, 4.0 mm)
Needle Stroke	31 mm
Presser Foot Lift	For 5.6 mm of needle distance with spreader: 5.5 mm, without spreader: 7.0 mm
Feed Regulation	By adjusting screw (available for micro adjustment)
Differential Ratio	Standard: 1 : 0.9 - 1 : 1.4 1 : 0.9 - 1 : 1.8 (stitch length is 2.5 mm or less in max. normal differential) 1 : 0.6 - 1 : 1.1 (adjustable by changing position of feed bar connection)
Differential Feed Regulation	Micro adjustment by adjuster Adjustable by moving external lever even during operation
Lubrication	Lubrication automatically by trochoid-shaped pump
Lubricating Oil	YAMATO SF OIL No. 28
Capacity of Oil Reservoir	800 cc
Installation	Table top type or semi-submerged type

***Yamato***

ヤマトミシン製造株式会社

***YAMATO SEWING MACHINE MFG. CO., LTD.***

4-4-12, NISHITENMA, KITA-KU, OSAKA, JAPAN  
TEL : 81-6-6364-1321 FAX : 81-6-6364-1307

〒530-0047 大阪市北区西天満4丁目4番12号  
TEL(06)6364-1321(代) FAX(06)6365-5176